

SUPPORTING AVIATION FROM THE GROUND UP

# GROUND SUPPORT

## WORLDWIDE

CHARLATTE OF AMERICA



VERDE GSE

DAVID CLARK



ENGINE DISTRIBUTORS



BETA FUELING SYSTEMS



WASP



## 2014-2015 INDUSTRY SHOWCASE

NOVEMBER 2014



UNITRON

# Aviation refueling equipment made



JON DeLINE // President and CEO

More than 40 years fueling aviation in over 30 countries

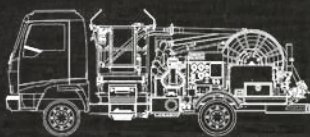

HYDRANT DISPENSERS

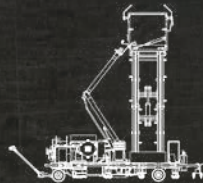

HYDRANT CARTS

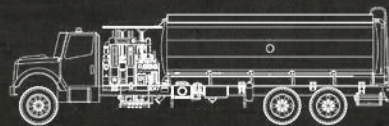

AVIATION REFUELERS

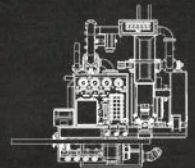

REFUELING MODULES

BETA is committed to your mission: **Turning your fuel into profits.**<sup>TM</sup>

BETA refueling equipment is used more than any other by the world's leading suppliers of ground services and fuel. We have earned this business through superior reliability, outstanding support, and delivery. That is The Beta Way<sup>TM</sup>.

**Trust The BETA Way<sup>TM</sup> to turn your fuel into profit.**



**RELIABILITY | SUPPORT | DELIVERY**<sup>TM</sup>

[betafueling.com](http://betafueling.com)

BETA Fueling Systems is part of the Alfons Haar Group.

+1 336 342 0306 // Reidsville, NC, USA

# GROUND SUPPORT WORLDWIDE

**Editor Steve Smith**  
920.563.1644 steve.smith@AviationPros.com

**Associate Publisher/  
Sales Missy Zingsheim**  
920.563.1665 missy@AviationPros.com

**Classified Advertising Michelle Scherer**  
920.568.8314 mscherer@AviationPros.com

**International  
Sales Manager Lutz Krampitz**  
+49 0 203 456 82 66 fax +49 0 203 456 85 38  
info@krampitzVv.de

Germany, Switzerland, Austria, Turkey, Scandinavia

**International  
Sales Manager Stephanie Painter**  
+44 1634 829386 fax +44 1634 281504  
Stephanie@painter-lowe.com  
United Kingdom, France, Netherlands, Spain, Ireland, Italy

**List Rental Elizabeth Jackson**  
847.492.1350 ext. 18 ejackson@meritdirect.com

## Production & Circulation

**Art Director Rhonda Cousin**

**Media Production Rep Carmen Seeber**  
920.568.8373 carmen.seeber@AviationPros.com

**Circulation Manager Debbie Dumke**  
**Production Director Steve Swick**

## GSE Expo Worldwide

**Trade Show Director Sue Ralston**  
920.568-8389 sue@AviationPros.com

Published by:



## Cygnus Aviation, Technology and Transportation Group

**Gloria Cosby** – Executive Vice President

**Gerry Whitty** – VP, Marketing

**Brett Ryden** – Publisher, Aviation Group

**Lester Craft** – Director of Digital Business Development

## Cygnus Business Media

**John French** – CEO

**Paul Bonaiuto** – CFO

**Julie Nachtigal** – VP, Audience Development

**Eric Kammerzelt** – VP, Technology

**Ed Wood** – VP, Human Resources

**Curt Pordes** – VP, Production Operations

Published and copyrighted 2014 by Cygnus Business Media, 1233 Janesville Ave., Fort Atkinson, WI 53538 USA. All rights reserved. No part of this publication may be reproduced or transmitted in any form or by any means, electronic or mechanical, including photocopy, recording or any information storage or retrieval system, without written permission from the publisher.

**Cygnus Reprint Services**  
To purchase article reprints, please contact Wright's Media at 877.652.5295 or email info@wrightsmedia.com.

**Subscription Policy:** Subscriptions are free to qualified businesses. Others may purchase subscriptions at these rates: US, 1-year \$45, 2-years \$85; Canada & Mexico, 1-year \$65, 2-years \$120; All other countries, via airmail, 1-year \$95, w-years \$180. Single copies \$10.

**Ground Support Worldwide** (USP 015-386, ISSN 1934-2861 print, ISSN 2150-4016 online) is published ten times annually in February, March, April, May, June/July, August, September, October, November and December/January. Periodicals postage paid at Fort Atkinson, WI and additional mailing offices.

Change of address or subscription information: Toll Free – 877-382-9187, Local – 847-559-7598, circ.groundsupportww@omedia.com

POSTMASTER: Please send address changes to *Ground Support Worldwide*, Cygnus Business Media, PO Box 3257, Northbrook, IL 60065-3257. Printed in the U.S.A.

Canada Post: PM40612608. Return undeliverable Canadian addresses to: Ground Support Worldwide, PO Box 25542, London, ON N6C 6B2. Canadian GST #R42773848.

# CONTENTS

**4 Associate Publisher's Note/Ad Index**

**6 Cargo/Baggage Handling Equipment & Accessories**

**12 Catering Equipment**

**14 Deicing/Anti-Icing**

**20 Fuels/Filters/ Equipment & Services**

**24 GPUs/Air Starts/PCAs/ Parts & Accessories**

**28 Green Products & Alternative Technology**

**30 Ground Handlers/ Service Providers**

**34 LAV/Potable Water Carts & Accessories**

**36 Maintenance & Shop Equipment**

**40 Passenger Stairs/Lifts/ Boarding Bridges**

**42 Pushbacks/Tractors/ Utility Vehicles**

**46 Safety & Communications**

**49 Classified Advertising**

**50 Editor's Note**



6



12



14



20



24



28



30



34



36



40



42



46



Missy Zingsheim

## GSE Expo is Back!

*Next year's show returns to its GSE heritage.*

*By Missy Zingsheim*

It is my pleasure to announce that we are returning to our roots and officially calling our show, GSE Expo. I know what you are thinking: "Wasn't that always the name?" Or "That is what I have always called it!"

The show has had several different names over the years because we have had more than one segment of aviation involved in the event. Well not anymore. In 2015 we

will be the only show focused on ground support in North America.

With our focus being on only GSE for 2015 we have scheduled more times where you can network with other ground support professionals, really bringing together the ground support community. Join us for great events like the **2<sup>nd</sup> Annual GSE Leaders Golf Invitational** on March 9 or our **Ground Support Leaders Awards Ceremony** on the show floor March 10. Don't forget to register for your FREE pass until January 15, 2015 at [www.gseexpo.com](http://www.gseexpo.com).

Come join **Ground Support Worldwide** and **GSE Expo**, March 10-11, 2015 in Las Vegas at the Sands Convention Center.

Missy Zingsheim  
Associate Publisher



Presented by  
**GROUND SUPPORT**  
WORLDWIDE

### Advertiser's Index

Advertiser	Page #	Advertiser	Page #	Advertiser	Page #
A T Juniper.....	45	Engine Distributors.....	52	Liquid Controls .....	14
AERO Specialties .....	43	Flightcom.....	35	Malabar.....	21
Anderson Airmotive Products Co, Inc.....	47	Gammon Technical Products, Inc. ....	31	Maxpro.....	39
ASIG .....	25	Global Ground Support.....	41	Mercury GSE.....	48
Beta Fueling Systems .....	2	GSE Expo.....	18-19	Mototok.....	33
Charlatte.....	7	GSE Intl.....	48	Page Industries.....	32
Columbus Jack.....	13	Harlan Corp.....	29	Par-Kan.....	47
Curtiss-Wright .....	23	Hobart .....	45	PF Fishpole Hoists.....	44
David Clark Company ...	5, 17	Hydraulics Intl .....	38	Phoenix Metal Products, Inc. ....	43
		Lektro .....	46	Premier Engineering & Manufacturing .....	15
				Rotorcraft.....	34
				Servicore .....	46
				Telephonics .....	16
				U.S. Airmotive GSE .....	12
				Unitron .....	51
				Verde GSE.....	11
				Wasp.....	9
				Xcēd Aviation Services....	27



((( WIRELESS )))

# CLEAR COMMUNICATION FOR MORE EFFICIENT RAMP OPERATIONS WITH DAVID CLARK WIRELESS SYSTEMS

David Clark Company Wireless Headset Communication Systems provide clear communication and greater mobility for more efficient and time-saving pushback operations, deicing and a variety of other ground support applications. Rugged components include wireless gateways, controllers and noise-attenuating headsets that allow crew members to communicate up to 300 feet from the wireless gateway or controller, without being tethered to the aircraft or equipment.

For more information  
call **508-751-5800** or  
visit **[www.davidclark.com](http://www.davidclark.com)**

Made In USA



[WWW.DAVIDCLARK.COM](http://WWW.DAVIDCLARK.COM)

# CARGO/BAGGAGE HANDLING EQUIPMENT & ACCESSORIES



## 660 Belt Loader

### TUG Technologies Corporation

With the heaviest chassis in its class, the TUG 660 belt loader assures years of dependable service in the most demanding ramp applications. The central mounted conveyor is elevated at both ends by lift arms that are activated by single-stage, double-acting cylinders.

[AviationPros.com/  
company/10025876](http://AviationPros.com/company/10025876)



## Container/Pallet Loader TLD

TLD offers three main container and pallet loaders: Model 838 with 16,500-pound capacity; Model 929 with 33,000-pound and 44,000-pound capacity and the Model 121 with 66,000-pound capacity. Operators and maintenance personnel can appreciate the speed, ease-of-operation and industry-leading diagnostics on all TLD loaders.

[AviationPros.com/company/10025391](http://AviationPros.com/company/10025391)



## Power Stow Rollertrack System

### Power Stow A/S

Power Stow's Rollertrack System is a versatile belt loader extension that allows for one-man bulk loading of narrow body aircraft holds. This system offers our customers the opportunity to save money on aircraft fuel by removing heavy onboard loading systems or to control manpower cost by eliminating the need for a two-man, belly-loading operation. Power Stow's Rollertrack System can be attached to most major brand belt loaders.

[AviationPros.com/company/10300843](http://AviationPros.com/company/10300843)

## Baggage Carts

### Par-Kan Company

Par-Kan Company offers both open and covered baggage carts.

- 4,000-pound Capacity
- 5,000-pound Capacity
- 8,000-pound Capacity
- 5th Wheel Steering
- Towbar Activated Braking System
- Pneumatic or Solid Tire Options Available
- Fixed or Torsion Axles Options Available
- Curtains and Tarp Systems Available
- Knock Down Cart Options Available for Sea Container Shipments
- Powdercoat Finish



[AviationPros.com/company/10025701](http://AviationPros.com/company/10025701)



## Electric Tugs/Beltloaders Somerset Capital Partners

New electric baggage tugs and beltloaders from 12,000-pound capacity to 30,000-pound capacity. Models include eTug Lite, DC20, DC30 and the eBeltloader.

[AviationPros.com/company/10276573](http://AviationPros.com/company/10276573)

## CBL2000E

### Charlotte of America

AC powered 80V full-size electric belt loader with 25 foot conveyor. Direct Drive belt system with flush-mounted weather-proof controls. Majority of components compatible with T137 tractor.

[AviationPros.com/company/10027110](http://AviationPros.com/company/10027110)





**IT'S ELECTRIC.**

# CARGO/BAGGAGE HANDLING EQUIPMENT & ACCESSORIES



## CHAMP 300 Pallet/ Container Loader

Trepel Airport Equipment  
GmbH

Trepel Airport Equipment GmbH has designed the CHAMP 300 pallet/container loader that is a self-propelled unit designed to handle containers and pallets up to 20 feet in length and a maximum of 30 tons. The 300 is capable of operating with a bridge platform height between 2 meters and 5.6 meters and can service main and lower deck compartments of a Boeing 747, DC-10, L-1011, and A300 aircraft.

[AviationPros.com/company/10024574](http://AviationPros.com/company/10024574)



## Cargo Restraint Products

Cargo Systems Inc.

Cargo Systems provides a full line of cargo restraint products. If you need something simple like a mil-spec strap, tie-downs, fittings, or attachment hardware, we've keep hundreds of parts in stock. If you require a custom-designed cargo restraint system for your aircraft, or ground vehicle, the company can assist with that as well. It has engineering capabilities, and a production team that can design and produce something to meet your needs within days.

[AviationPros.com/company/11117483](http://AviationPros.com/company/11117483)



## Fire-Resistant Cargo Containers

AAR Corp.

AAR announced a new Nordisk ULD design, which during testing was proven to contain a fire for up to six hours. Partnering with DuPont, AAR was able to replace traditional construction with innovative materials for a unit that is lighter than any similar product on the market.

[AviationPros.com/company/11135441](http://AviationPros.com/company/11135441)



## Five Power Options

NMC-Wollard Inc.

NMC-Wollard Model TC-888 Belt Loader is available with electric, gas, diesel, LP, and dual fuel

power (each with automatic transmission). All power types are emission-compliant, except diesel, which conforms to the TPEM (or FLEX) program. The TC-888 baggage conveyor features a unitized, tubular, impact-deflecting chassis. Modular engine/transmission power pack makes maintenance and repair simple.

[AviationPros.com/company/11076581](http://AviationPros.com/company/11076581)

## Standard Dolly

Wasp Inc.

Due to the many types and combinations of containers and pallets it can handle, Wasp's one New Standard Dolly can replace multiple dollies with various capacities. The New Standard Dolly has a 15,000-pound (6,804-kilogram) capacity and the versatility to carry LD-2, LD-3, LD-4 and LD-11 containers, as well as two LD-2 or LD-3 containers at a time. It also takes half pallets, 88-by-125-inch (224-by-318-centimeter) pallets and 96-by-125-inch (244-by-318-centimeter) pallets. LD stops and vertical restraints throughout the unit firmly lock containers in place.

[AviationPros.com/company/12017895](http://AviationPros.com/company/12017895)



## Baggage Chute

PAGE Industries

PAGE Industries presents the most modern and easy to install Baggage Chute available. PAGE introduces the P6000 Baggage Chute utilizing up-to-date manufacturing techniques which produce a lightweight and maintenance-free modern solution that is safe and convenient to use. No baggage chute is easier and quicker to install to help minimize costs.

[AviationPros.com/company/11201217](http://AviationPros.com/company/11201217)



## Baggage Cart

R.J. Design LLC

New design of baggage carts includes a dead man switch on rear, floor stop brake on front. Lightweight aluminum holds 500 pounds on top shelf. Width holds two bags deep.

[AviationPros.com/company/11192254](http://AviationPros.com/company/11192254)

The logo consists of the word "WASP" in a bold, blue, sans-serif font, centered within a white oval. This oval is set against a blue, trapezoidal background that is part of a larger graphic element.

# GET MOVING

QUALITY. SAFETY. SOLUTIONS.



*STAIRS*



*DOLLIES*



*BAGGAGE CARTS*



*BELT LOADERS*

In your business, movement is money — whether that's moving passengers or cargo. To keep moving safely, you need high-quality, low-maintenance, time-tested ground support equipment. Our full line is always ready to roll ... not to mention raise, haul and carry.

*Find out how the world's largest non-powered GSE manufacturer can keep you moving today.*

320.334.2868 // [GSE@WASPINC.COM](mailto:GSE@WASPINC.COM) // [WWW.WASPINC.COM](http://WWW.WASPINC.COM)

# CARGO/BAGGAGE HANDLING EQUIPMENT & ACCESSORIES



## Baggage Cart Curtains ABC Industries Inc.

ABC Industries, Inc. has expanded its GSE product offering with a new line of baggage cart curtains. Available for baggage, freight, mail and catering, the cart curtains are custom designed to each cart OEM's specification. A series of carabiner hooks are used to quickly attach and detach the curtain, eliminating time consuming and costly maintenance. The curtains are constructed of high-strength, 20-ounce ABC VentaTex® PVC fabric.

[AviationPros.com/company/10732974](http://AviationPros.com/company/10732974)



## High Speed Cargo Tractor Eagle Tugs

Eagle Tugs was the originator of the Bob Tail high-speed cargo tractor more than 40 years ago and is still the leader today. Eagle Bob Tails can tow cargo up to 90,000 pounds. (40,823 kilograms).

[AviationPros.com/company/11191672](http://AviationPros.com/company/11191672)



## Conveyor Belting HBD/Thermoid Inc.

Thermoid® PACK-EZ S/Weave conveyor or belting is approved and preferred by all major, package handling companies. Especially suited for slider bed systems, these belts are built to resist abrasion, stretching and fire.

[AviationPros.com/company/11191802](http://AviationPros.com/company/11191802)

## Cargo, Baggage Tractor SCHOPF Maschinenbau GmbH

The Rofan ZH5 is capable of towing loads up to 35 tonnes. With a drawbar pull of more than 20,000 N and equipped with the 64 kW Deutz TD2012 engine, the ZH5 can be used for heavy-duty cargo and baggage applications. The fast, flexible PowerHybrid system is unique in providing both diesel speeds outdoors and emission-free operations indoors, which enables the ZH5 to deliver goods in half the time.

[AviationPros.com/company/10027541](http://AviationPros.com/company/10027541)



## Covered Pallet Trailer Clyde Machines Inc.

The 15F2862 15,000-pound capacity trailer has a new recessed frame to protect customer markings. This Covered Pallet Trailer will hold LD1, 2, 3, 4, 7, and 8 containers, or 88-inch x 125-inch, 96-inch x 125-inch, and 88-inch x 108-inch pallets. With its actuated towbar, self-adjusting rear brakes and 4 x 8, three-stage solid tires, this durable trailer is a Clyde featured product with a quality powder coat finish.

[AviationPros.com/company/10779066](http://AviationPros.com/company/10779066)

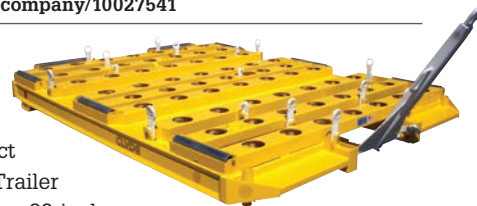

## Customized Baggage/ Cargo Equipment MP Industries Inc.

MP Industries offers several models of cargo and baggage handling equipment and accessories to suit your needs. All of our products may be customized.

[AviationPros.com/company/12014134](http://AviationPros.com/company/12014134)



## Durable Textile Solutions Estex Manufacturing Co. Inc.

Estex Manufacturing providing quality and durable textile solutions to GSE for over 25 years. PCA Hoses, Loading Bridge Canopies, Cart Curtains, ULD Doors and our NEW Cabin Service Truck Doors which replace costly and labor intensive roll-up doors on current truck fleet.

[AviationPros.com/company/12013143](http://AviationPros.com/company/12013143)

## Commander Cargo Loaders JBT AeroTech, Jetway Systems

JBT AeroTech offers a range of cargo loaders capable of servicing lower and main deck cargo. All Commander use the HeliRoll conveys system, which has revolutionized aircraft container and pallet handling. A PLC-based electrical system and swing out power model provide quick access for maintenance servicing. JBT's cargo loaders are available in a wide variety of sizes and configurations and have load ranges of 8,000 to 60,000 pounds.

[AviationPros.com/company/10024639](http://AviationPros.com/company/10024639)





# PRE CONDITIONED AIR

## 30, 60, 90, & 120 TON PCA

### SIMPLE MACHINE

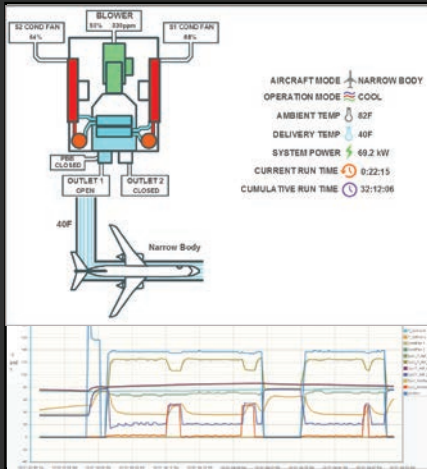

VERDE-ICE online monitoring



Verde 60 Ton PCA system at Orlando International Airport

### DYNAMIC PERFORMANCE

#### FEATURES

**REMOTELY MONITOR, TROUBLESHOOT, & COLLECT PERFORMANCE DATA FROM EACH GATE LOCATION**

**LOWEST REFRIGERANT CHARGE PER TON**

**SEAMLESS DEFROST**

**HIGH ENERGY EFFICIENCY WITH BLOWER & FAN SPEED CONTROL**

**MICROCHANNEL HEAT EXCHANGERS**

**INDUSTRY'S FIRST HEAT PUMP**

**ENHANCED EVAPORATORS**



Verde 60 Ton PCA system at Sarasota International Airport

**FOR A QUOTE**

**CALL - (888) 837-5221**

**EMAIL - sales@verdegse.com**

**WEBSITE - www.verdegse.com**

**LEASING PLANS AVAILABLE**

**WWW.VERDEGSE.COM**



PROUDLY MADE  
IN THE USA



# CATERING EQUIPMENT



## Pnx-PV120 Provisioning Van

Phoenix Metal Products



Phoenix PV120 Provisioning Van is a self-contained vehicle that can service

aircraft with a door height from 98 inches to 108 inches. The van body is fixed with an elevating platform. A parallelogram stair makes a safe transition between the van body and platform.

[AviationPros.com/company/10026497](http://AviationPros.com/company/10026497)

## Catering/Cabin Service Trucks Global Ground Support

Catering/Cabin Service Trucks are available in various sizes: 18-foot wide body, 22-foot wide body, 16-foot narrow body and 14-foot narrow body. RJ 1/2 cab service also available.

[AviationPros.com/company/10026400](http://AviationPros.com/company/10026400)

**NEW CRUSH PROOF LAVATORY DUMP HOSE**

You can Run over it, Smash it or Drag it and STILL USE IT!

CRUSH PROOF LAV HOSE    WATER HOSES, COUPLINGS AND FITTINGS    LAV COUPLINGS AND FITTINGS

GSE PRODUCTS    GSE PARTS

ATTACHABLE PLUGS AND RECEPTACLES    AC/DC CABLE PROTECTOR COVER    JET STARTER HOSES AND COUPLINGS    **NEW** FULLY WELDED PCA HOSE

**CELEBRATING 50 YEARS!**

HOSES: LAVATORY DRAIN-BLUE & POTABLE WATER-PCA-AIR/HEAT-JET STARTER  
COUPLINGS FITTINGS AND CONNECTORS • CASTERS • WHEEL CHOCKS • DAVID CLARK  
LAV METERS • PARTS FOR TUG • HOBART • TRILECTRON • PARKAN • FMC • CLYDE

CONVEYOR BELTS • SAFETY VEST • DIRECTIONAL WAND • TOW BARS • CARGO NETS  
STRAPS • TIEDOWN RINGS • MATERIAL HANDLING AND MORE



**MAIN FLORIDA OFFICE**  
P.O. Box 660474  
Miami Springs, Florida 33266  
Tel: 305.885.4992 Fax: 305.885.9537  
Email: [sales@usairmotivegse.com](mailto:sales@usairmotivegse.com)

**CALIFORNIA SALES OFFICE**  
2110 Artesia Blvd. # B209  
Redondo Beach, California 90278  
Tel: 310.327.8407 Fax: 310.327.8439  
Email: [paula@usairmotivegse.com](mailto:paula@usairmotivegse.com)

[www.usairmotivegse.com](http://www.usairmotivegse.com)

[AviationPros.com/company/10017906](http://AviationPros.com/company/10017906)



## Flight Catering Hi Lift Nandan GSE Pvt. Ltd.

Nandan manufacturers Hi Lifts for Catering companies who want economical and world class solutions. Standard is 4 ton with FRP panel bodies and four way platform. We can customize every feature and choose the model depending on your exacting need. Chassis, refrigeration unit and transmission of choice.

[AviationPros.com/company/10027554](http://AviationPros.com/company/10027554)

## CATERING EQUIPMENT



### 'Ecat' Catering Truck DOLL Fahrzeugbau AG

The ecat is powered by emission-free electric engines whose energy is supplied by high-performance batteries, which can be charged anytime at the ramp. In this way, CO<sup>2</sup> emissions are reduced to zero and the energy consumption as well as noise pollution decrease considerably. Furthermore, a more efficient energy carrier and low motor maintenance requirements contribute to lowering operating costs and to increasing the vehicle's efficiency. The driving innovation is completed by a novel intelligent driving assistance which is characterized by warning and safety systems minimizing downtime as well as maintenance costs.

[AviationPros.com/company/11245336](http://AviationPros.com/company/11245336)



### Catering Truck Stinar Corporation

Stinar Corporation offers its HLCA-722 Catering Truck that services aircraft from 98 to 228 inches and features:

- 22-ft. van body.
- Four vertical stabilizers.
- Front and rear roll-up doors.
- Aluminum diamond plate floor.
- Many options available including refrigeration.

[AviationPros.com/company/10024780](http://AviationPros.com/company/10024780)

# WE KNOW GSE!

Hand Carry Axle Jacks  
3 to 25 Tons



Single Acting Alligator Axle Jacks  
35 to 95 Tons



Fly-A-Way Axle Jacks  
35 to 95 Tons



Power Retract™ Alligator Axle Jacks  
65 to 95 Tons

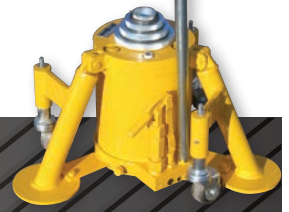
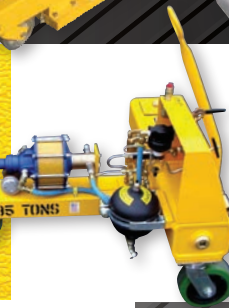

Bead Breakers



Tripod Jacks  
3 Tons to 125 Tons



Wheel & Brake Dollies



Portable Floor Cranes

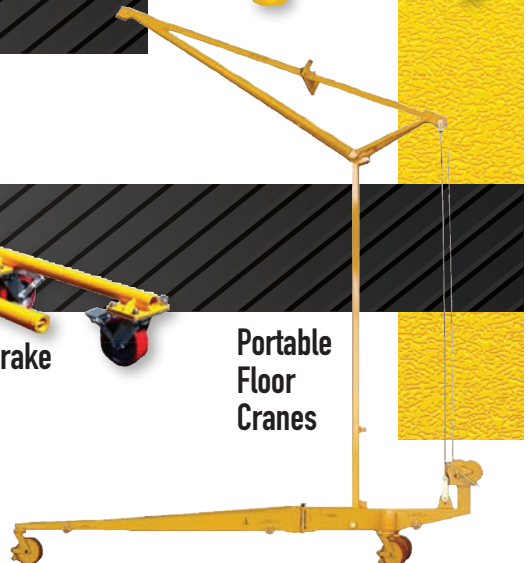

## Columbus JACK/Regent

*"The Strength of Experience"*

2222 S. Third St., Columbus OH 43207  
Ph: (614) 443-7492 Fax: (614) 444-9337

[sales@columbusjack.com](mailto:sales@columbusjack.com) ■ [www.columbusjack.com](http://www.columbusjack.com)

ISO 9001:2008

[AviationPros.com/company/10134078](http://AviationPros.com/company/10134078)

# DEICING/ ANTI-ICING



## Deicer Rentals

### Fortbrand Services, Inc.

Fortbrand Services provides seasonal and long-term rentals of aircraft deicers.

[AviationPros.com/company/10026906](http://AviationPros.com/company/10026906)



## Glycol Blending And Management Liquid Automation Systems (LAS-USA)

LAS manufactures a broad range of glycol blending and management products. Our Glycol Pro line of blenders are the most accurate, reliable and easy to use on the market today. Glycol Pro systems enable you to re-blend fluids in the truck to meet new freeze point requirements due to changing weather conditions. These products enable you to more than double your deicing fluid capacity on site without adding a single tank, and cut your ADF fluid transportation costs in half.

[AviationPros.com/company/10959026](http://AviationPros.com/company/10959026)

## Tempest Deicers

### JBT AeroTech, Jetway Systems

Tempest deicers offer green solutions that reduce glycol use by up to 50 percent. AirFirst® forced air is very effective with frost using 9-12 gpm of fluid. Proportional mix with BlendUP allows operators to set glycol to water ratio based upon local weather and does not require external heat or purging.

[AviationPros.com/company/10027426](http://AviationPros.com/company/10027426)



# FlightConnect

## SIMPLICITY IN INTO-PLANE FUELING

FlightConnect is an aviation fueling system that captures into-plane fueling data on the tarmac and wirelessly uploads it into a spreadsheet (or another type of accounting software) in your office.

### SIMPLE

- Fuelers follow guided, configurable fueling screens. Data uploads into accounting software sorted and indexed.

### SINGLE-SOURCE

- No external device required. All fueling commands on LectroCount LCR 600.

### STREAMLINED

- Automated data capture and wireless data transfer.

### SAVINGS

- No "per transaction" fees applied.

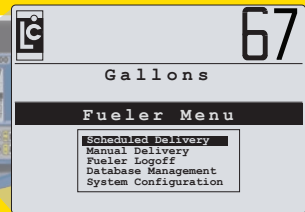

LCR 600 FlightConnect  
Fueling Screen

**"It truly couldn't be any simpler."**

Joe Freeman, Facilities and Maintenance  
Manager for Million Air of Addison Airfield

Spreadsheet with FlightConnect Fueling Data

ID	Date Time	Owner	Unit #	Fueler	Reference	Begin Delivery
1365931	09/22/14 11:17:35	LC	1	00	09221206	09/22/14 11:17:00
1365932	09/22/14 11:54:31	LC	1	00	09221379	09/22/14 11:54:04
1365937	09/22/14 14:54:04	LC	1	00	09221003	09/22/14 14:53:23
1365938	09/28/14 14:58:19	LC	1	00	09281104	09/28/14 14:57:04
1365939	09/28/14 15:24:19	LC	1	00	09281105	09/28/14 15:24:03
1365940	09/28/14 15:24:52	LC	1	00	09281106	09/28/14 15:24:25
1365941	09/28/14 15:25:32	LC	1	00	09281107	09/28/14 15:25:11

Come visit us in **BOOTH 1804** at the  
**2014 NBAA  
SCHEDULERS & DISPATCHERS CONFERENCE**

M-80 Positive Displacement  
Flowmeter with LCR 600

Simplify your fueling operations with FlightConnect.  
Contact us at [icm-info@flightconnect.com](mailto:icm-info@flightconnect.com) or **847-612-6396**



[AviationPros.com/company/10017539](http://AviationPros.com/company/10017539)



## Express Heat Deicer

**Premier Engineering and Manufacturing**

Premier Engineering and Manufacturing's Model MT43P21 "Express Heat" Deicer contains 2,100 gallons of fluid storage capacity with 180-degree F fluid within 90 seconds utilizing the "Express Heat" 4.2 million BTU heating system. A double knuckle, telescoping and articulating aerial lift is forward-mounted for greater versatility and visibility of the operator.

[AviationPros.com/company/10025553](http://AviationPros.com/company/10025553)

## Towable Deicer

**AERO Specialties**



AERO Specialties offers no fuel burn, turn-key deicing solutions with its fleet of Trumpf TD-300 towable deicers complete with glycol and collapsible towers. Available for rent, lease, or purchase. With rising fuel costs, these units are the most cost-effective deicers available for servicing regional and business jets.

[AviationPros.com/company/10026744](http://AviationPros.com/company/10026744)



## GS Series Deicers

**Ground Support Specialist LLC**

GSS manufactures the GS Series 800- and 1,400-gallon deicers on a purpose-built chassis powered by a single engine. The GS Series Deicers are designed for use on a wide range of aircraft. The 1,400 gallon deicers are available with an enclosed basket with or without forced air.

[AviationPros.com/company/10441109](http://AviationPros.com/company/10441109)

## Deicing Nozzles

**U.S. Airmotive GSE**

U.S. Airmotive GSE is proud to be a distributor of deicing nozzles manufactured by Task Force Tips. A single nozzle can be used in two steps to both deice and anti-ice aircraft. The operator simply selects the desired fluid delivery system pressure, and the nozzle responds automatically. TFT backs its nozzles with a five-year warranty.

[AviationPros.com/company/10724697](http://AviationPros.com/company/10724697)



## MODEL MT65P21 "EXPRESS HEAT" DEICER

The "Premier" Model MT65P21 "Express Heat" Deicer utilizes the Versalift Extended Reach Model VST6000 Aerial lift, providing 65' of working height.

More important, the MT65P21 incorporates the *Premier* boom forward design to provide the maximum amount of reach off the front of the vehicle utilizing the rapid deploy down riggers. During mobile operations, side reach of 34' and vertical reach of 46' can easily be accomplished.

**Premier**  
ENGINEERING & MANUFACTURING, INC.  
*Simple, Dependable and Affordable*

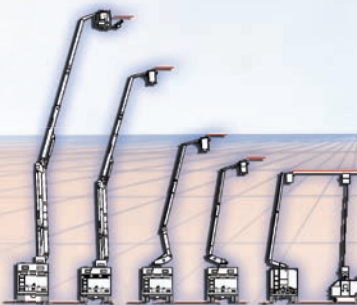

"Express Heat" reliability, easy access maintenance, extend reach capabilities, and lowest cost of operation is why we are the "Premier" deicer manufacturer.



**Tel - 715-735-6440, [www.premier-deicers.com](http://www.premier-deicers.com)**

[AviationPros.com/company/10017675](http://AviationPros.com/company/10017675)

## DEICING/ANTI-ICING

### Deicer Equipment: One Source, Comprehensive Selection Sage Parts Inc.

Sage Parts is your one-stop source for the finest deicer parts. Our extensive range of top branded products includes but not limited to the high capacity and self-priming Hardi® Deicer Pump 463 and the industry-standard Task Force Tips® Ice Control Nozzle with Pistol Grip. Also available from Sage are top quality David Clark® Headsets and Remote Station Control, as well as the SOOTOMAGIC™ Soot Stick...the original and best soot stick.



[AviationPros.com/company/11486618](http://AviationPros.com/company/11486618)

### Glycol Recovery Vehicle Global Ground Support

Global Ground Support's Glycol Recovery Vehicle is mounted on an Isuzu NPR HD equipped with automatic transmission, a 5.1-liter engine and 113-liter fuel tank. However, the unit can be mounted on any appropriately sized chassis. The vacuum and hydraulic systems are powered by an auxiliary engine, a Deutz oil-cooled three-cylinder diesel. This drives a 850-cfm positive displacement blower and provides hydraulic power for the electric over hydraulic controls.



[AviationPros.com/company/10027698](http://AviationPros.com/company/10027698)



### UCAR™ Aircraft Deicing/ Anti-icing Fluids

#### Dow Chemical Co., The

UCAR™ aircraft deicing and anti-icing fluids from The Dow Chemical Company help protect the safety and on-time performance of winter-weather flight operations. Dow's product line includes Type I deicing fluids and Type IV deicing and anti-icing fluids, in propylene glycol and ethylene glycol formulations to help meet specific user requirements.

[AviationPros.com/company/10727239](http://AviationPros.com/company/10727239)

## ALL CLEAR: Communicate with Confidence

### TruLink® Wireless Intercommunications System



From the flightline to the frontline, TruLink provides safe and secure communications, reducing ambient noise during engine testing and pre-flight maintenance.

For more information, email [RSDCRC@telephonics.com](mailto:RSDCRC@telephonics.com) or call +1.631.755.7185.



[www.telephonics.com](http://www.telephonics.com)

39425 © 2014 Telephonics Corporation. All Rights Reserved.

[AviationPros.com/company/12014696](http://AviationPros.com/company/12014696)



## Glycol/Water Blending System

### Kerrigan Corporation

The Kerrigan glycol/water blending system is a safe, reliable method for blending Type I glycol. Kerrigan Corp. also designs, manufactures and installs deicing and anti-icing storage and distribution systems.

[AviationPros.com/company/10024547](http://AviationPros.com/company/10024547)



## Mobile Deicer Carts

### Tronair Inc.

Tronair's Mobile Deicer Carts deliver Type 1 fluid efficiently and effectively; the units come in a variety of voltages. Tronair also manufactures a unit designed specifically for servicing TKS anti-icing fluid reservoirs. The TKS unit is lightweight and easy to use, says the company.

[AviationPros.com/company/10447488](http://AviationPros.com/company/10447488)

## DFsustain

### Kilfrost Limited

As the world's first Type I deicing fluid based on glycol from a sustainable source, DF<sup>sustain</sup> outperforms all existing propylene glycol deicers and can cope with temperatures up to minus 40 degrees F. Eco-friendly, it has the potential to use 40 percent less energy in manufacturing than traditional fluids.

[AviationPros.com/company/10027574](http://AviationPros.com/company/10027574)



## Ice Control Nozzles

### Task Force Tips Inc.



Task Force Tips Ice Control Nozzles have been specifically designed to apply water-, glycol-, or water/glycol-based deicing and anti-icing fluids to aircraft exterior surfaces at fluid temperatures up to 210 degrees F (99 degrees C). The proper use of deicing and anti-icing agents aids ground-support professionals in the removal of frozen precipitation from aircraft fuselage, landing gear, and wing surfaces and helps prevent ice and snow from adhering to the wings of aircraft.

[AviationPros.com/company/10441669](http://AviationPros.com/company/10441669)



# RADIO DIRECT

**Improve Ramp Efficiency  
 with David Clark Series 6200 Headsets  
 for Two-Way Communications.**

Ramp communication is clear and simple with David Clark Company Series 6200 headsets designed to *connect directly* to a wide variety of portable radios *with no adapter required*. Push-to-Talk switch is located conveniently on the headset dome for ease of communication. For more information call **800-298-6235**.

Scan to find the right headset for your radio



[AviationPros.com/company/10017163](http://AviationPros.com/company/10017163)

# GSE EXPO WORLDWIDE

*Presented by*

**GROUND SUPPORT**  
WORLDWIDE

***Supporting Aviation  
from the Ground Up***

**MARCH 10-11, 2015**

Las Vegas, Nevada

The Sands Expo Convention Center

Visit [www.GSEexpo.com](http://www.GSEexpo.com)

# YOU SPOKE, WE LISTENED



The only North American event solely focused on GSE in 2015.

Learn about products and services from more than 100 leading solution providers.



Networking opportunities with exhibitors and fellow attendees.

Las Vegas is the ideal location to combine business and pleasure.



**Register by January 15  
for your  
FREE expo badge!**

**Use Promo Code GSEGSW2015**

BROUGHT TO YOU IN PART BY:

**airport**  
business

SPONSORED BY:

**NATA**  
National Air Transportation Association  
The Voice of Aviation Business

**NVBAA**  
NEVADA BUSINESS AVIATION ASSOCIATION

**for registration information!**

# FUELS/FILTERS/ EQUIPMENT & SERVICES



## Stainless Steel Reels Hannay Reels Inc.

Hannay Reels static grounding cable reels are now available in 304-grade stainless steel construction for its HGR Series. Stainless steel protects reels against rust, corrosion and eliminates paint maintenance, making it ideal for harsh work environments or outdoor installation.

[AviationPros.com/company/10740913](http://AviationPros.com/company/10740913)



## 800 GPM Hydrant Dispenser BETA Fueling Systems

BETA Fueling Systems is a global leader in the design and manufacture of aviation hydrant dispensing equipment. With hundreds of units currently in service at major airports around the globe delivering fuel at 800 GPM to 1000 GPM flow rates, BETA dispensers perform reliably for the most demanding oil companies, airlines and aviation fueling companies.

[AviationPros.com/company/12018195](http://AviationPros.com/company/12018195)

## Fuel Service Cart Par-Kan Company

The FSC-550 Fuel Service Cart Par-Kan offers a convenient way to fuel ramp equipment. The cart features solid steel construction, a 550-gallon fuel tank, containment tank, fuel meter, rotary hand pump, static ground reel and fire extinguisher.

[AviationPros.com/company/10817906](http://AviationPros.com/company/10817906)



## Stainless Steel Inner Linings Garsite

Garsite has introduced stainless steel inner linings on double-wall tanks. While improving longevity and operational reliability, Garsite eliminates the epoxy coating and replaces it with a stainless steel inner tank, at the same cost to the customer. Replacing the carbon steel, epoxy-coated inner tanks with a stainless steel inner tank will add years of uninterrupted service to the life of an above-ground fueling system.

[AviationPros.com/company/10027727](http://AviationPros.com/company/10027727)

## PerformaFuel Integrated Inventory Control

### PerformaFuel Taughannock Aviation Corp. - Ground Support Equipment

Taughannock Aviation Corp. offers PerformaFuel an Aviation fuel management software solution built by an FBO for FBOs. PerformaFuel takes care of time consuming functions associated with aviation fuel ticket handling, inventory allocation, balancing, adjusting and reporting. Use the data being collected in the field to your advantage; from receipts, into-plane, defueling, truck fills and transfers -to- back office activity monitoring, reporting and EOM close outs. PerformaFuel integrates all fueling operations seamlessly. The result: A powerful multiple-inventory fuel management solution.

[AviationPros.com/company/11077265](http://AviationPros.com/company/11077265)



## FlightConnect Liquid Controls Group

FlightConnect is an automated, easy-to-use data management system. FlightConnect collects fueling details at the gate or at the plane and delivers them, wirelessly, to the doorstep of the back office software. FlightConnect accelerates into-plane fueling operations on the tarmac and in the office.

[AviationPros.com/company/10027223](http://AviationPros.com/company/10027223)

## 2014 Aviation Fueling Directory App Airport Business Magazine

The 2014 Aviation Fueling Directory, sponsored by EPIC, offers a handy guide to fueling suppliers along with a practical category index to help you find fuel and fueling equipment.

[AviationPros.com/company/11666170](http://AviationPros.com/company/11666170)





## Engine Management System Rampmaster

Rampmaster, the premier manufacturer of aircraft refuelers for the worldwide aviation market, has received the final testing report from West Virginia University's Center for Alternative Fuels, Engines and Emissions (CAFEE) confirming that an aircraft refueling vehicle outfitted with the company's patented Engine Management System (EMS) consumes up to 78 percent less diesel fuel while pumping its jet fuel, a worldwide first in diesel fuel savings and greenhouse gas emissions.

[AviationPros.com/company/10825688](http://AviationPros.com/company/10825688)



## Refueling Pumps The Gorman-Rupp Company

Gorman-Rupp's complete line of ground service pumps and related equipment have met the challenge of accelerated aircraft refueling and defueling requirements for more than 50 years. It also manufactures bulk transfer pumps, Shield-A-Spark engine driven pumps for handling volatile liquids and a unique Tankleenor system for use in removing contaminants and water from underground fuel storage tanks. Whatever your aircraft fueling requirements, Gorman-Rupp ground service pumps and related equipment will do the job.

[AviationPros.com/company/10453034](http://AviationPros.com/company/10453034)

## Differential Pressure Module - DPM Velcon Filtration Division, a Parker Hannifin Company

The DPM control unit continuously monitors the differential pressure between the inlet and outlet of a filter monitor or filter water separator vessel. Whether static or on-board hydrant carts or refuelers, the DPM monitors the condition of the filter elements. In the event that the filter differential pressure reaches maximum allowable pressure, the industrial strength relay on-board the DPM control unit breaks the deadman circuit, effectively terminating the refueling operation.

[AviationPros.com/company/10976317](http://AviationPros.com/company/10976317)



# A World Leader In Aircraft Maintenance Equipment



*Specialized Service Carts*



*Tripod and Axle Jacks*



*Fluid Dispensers*

220 W. Los Angeles Avenue • Simi Valley, CA 93065, USA  
Tel: 1-805-581-1200 • Fax: 1-805-584-1624 • [www.malabar.com](http://www.malabar.com)

**MALABAR™**  
INTERNATIONAL

[AviationPros.com/company/10017568](http://AviationPros.com/company/10017568)

## FUELS/FILTERS/EQUIPMENT & SERVICES

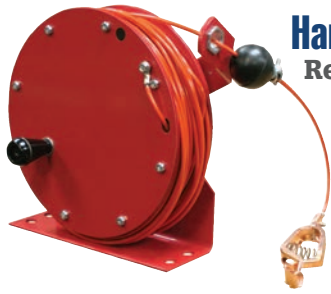

### Hand Crank Static Discharge Reel Reelcraft Industries Inc.

Reelcraft introduces an expansion in its line of industrial duty static discharge reels. The latest addition, our manual rewind GHC3100 N, conveniently retracts and stores up to 100-feet of high-visibility orange nylon jacketed cable. When properly clamped to a ground, the static discharge reel dissipates static electrical buildup, reducing the chances of sparking and the potential for

explosion. It is highly recommended for applications where explosions are prevalent as a result of static build-up, such as re-fueling/defueling.

[AviationPros.com/company/11076567](http://AviationPros.com/company/11076567)



### Integrated Fueling System Cavotec Ground Support System

Cavotec has launched a new fueling element to its innovative E3 Gate, making the E3 Gate one of the most uniquely integrated aircraft servicing systems available anywhere in the world. Cavotec's 3 Gate – so called because it is designed to deliver optimal performance in Ergonomics, Economy and the Environment – supplies parked aircraft with 400Hz power, PCAir, blue and potable water and sewage – and now fuel – via underground pit systems.

[AviationPros.com/company/11251115](http://AviationPros.com/company/11251115)



### Brawny Upgrade Coxreels

Coxreels® introduces the brawny upgrade available for any hand crank and motorized 1125 Series hose reel. The Brawny

reels are designed with 10-gauge steel plates welded into each disc to keep them from bowing. The center drum is thickened and upgraded from standard 16-gauge to 14-gauge steel to prevent deformation and eventual crushing of the drum that can be caused by hose pressure.

[AviationPros.com/company/10779326](http://AviationPros.com/company/10779326)



### Hydrant Dispenser Carts BETA Fueling Systems

For over 20 years, BETA has been the leader in the innovation of towable and self-propelled fueling carts capable of delivering from 450 GPM to 1000 GPM flow rates. BETA currently has over 1000 units operating in the world's busiest airports. Designed for high reliability in extreme climates, BETA carts are widely recognized for easiest operation, highest flow rates and lowest maintenance costs.

[AviationPros.com/company/12018195](http://AviationPros.com/company/12018195)



### TCS HUB

#### Total Control Systems

Total Control System's TCS HUB now features a customizable dashboard. Now, not only can you centralize your delivery information, you can see the information you need at-a-glance. Paired with the TCS 3000 electronic register, you can track real-time truck inventory, gauge daily/monthly throughput, and more!

[AviationPros.com/company/12013136](http://AviationPros.com/company/12013136)



### Wireless Tank Monitoring Liquid Automation Systems (LAS-USA)

Wireless tank monitoring from your PC and mobile device. Battery powered allows for low cost installation and web enabled, eliminating IT red tape. The perfect solution for monitoring glycol and fuel tanks within the complex and disjointed airport infrastructure.

[AviationPros.com/company/11193496](http://AviationPros.com/company/11193496)



### Gammon Technical Products

#### Gammon Technical Products Inc.

Gammon Technical Products is a manufacturer and distributor of aviation fuel (Jet and Avgas) equipment for quality control, handling and sampling, additive injection, static reels and cable, differential pressure gauges, overwing "Skyhawk" nozzle, bonding and grounding.

[AviationPros.com/company/12013911](http://AviationPros.com/company/12013911)



### Fuel Cabinets Sparling Corporation

Sparling designs, installs, and modifies aviation fuel storage systems. Fueling cabinets and portable fueling/defueling trailers. Large inventory of fueling equipment. On-site repairs.

[AviationPros.com/company/10817470](http://AviationPros.com/company/10817470)



## Fueling Accessories Fjord Aviation Products

Fjord Aviation Products manufactures urethane aviation ground fueling safety products such as fuel nozzle dust covers, replacement handle guards, wing mats for aircraft fueling/access protection, sealing dust covers for fuel ports on fuel trucks and hydrant systems in addition to supplying fuel quality testing and sampling products.

[AviationPros.com/company/10026433](http://AviationPros.com/company/10026433)

## Fueling Coupler Eaton



Eaton's Model 64910/64810 coupler's lower half have been completely redesigned. Incorporating three detent pins, an internal collar locking device and new collar lifting handle, this new design provides improved ergonomics and operational handling during disconnect.

[AviationPros.com/company/10441095](http://AviationPros.com/company/10441095)

## Flexible Fueling Hose Hewitt, A Husky Company



Hewitt delivers the state-of-the-art solution to carry aviation fuel to movable service platforms and lift decks. The new Hewitt 5500 Premium JacRiser has twice the flexing durability and is much easier to use than competing products, making it ideal for any application where flexible hose is needed to load or unload petroleum products.

[AviationPros.com/company/11111578](http://AviationPros.com/company/11111578)

## Self-Serve Fueling Terminal QT Petroleum On Demand



The Model 3000 Self-Serve Fueling Terminal sets the standard for retail automated fueling systems. Using a single integrated controller board, the M3000 has fewer parts than other systems. This uncomplicated design means simple maintenance, 24-hour self-service operation and better reliability (average up-time greater than 99 percent). With installations from Alaska to the Bahamas, the M3000 has proven to operate in the most extreme climates, providing reliable, maintenance-free service for pilots throughout the world.

[AviationPros.com/company/11545211](http://AviationPros.com/company/11545211)

Every flight begins here.



### Towbarless and conventional tractors for handling aircraft up to the Airbus A380

Douglas Tugmaster Towbarless Aircraft Tractors enable airlines and ground handling companies to reduce operational costs and increase operational flexibility and efficiency. They handle aircraft of all sizes from regional turbo-props and jets up to the Airbus A380.

Douglas Conventional Towing Tractors weighing 4 to 70 tonnes include tractors for baggage, equipment and cargo towing and for handling aircraft from general aviation and regional types all the way through to the A380.

**CURTISS  
WRIGHT**  
Flow Control Company  
**DOUGLAS**

**DOUGLAS**  
Tugmaster

To learn about our aircraft handling solutions, e-mail [sales@douglas-equipment.com](mailto:sales@douglas-equipment.com) or visit <http://douglas.cwfc.com>

[AviationPros.com/company/11318409](http://AviationPros.com/company/11318409)

# GSE EXPO WORLDWIDE

*Presented by*  
**GROUND SUPPORT**  
WORLDWIDE

## ***Supporting Aviation from the Ground Up***

*Network with industry leaders and reach decision-makers at GSE expo,  
the only event dedicated to serving the ground support professional.*

**MARCH 10-11, 2015**  
The Sands Expo Convention Center

**EXHIBITOR PROSPECTUS**

# SHOW SPONSORSHIPS: KEEP YOUR BRAND TOP-OF-MIND

Multiply the effectiveness of your show experience through our **GSE expo** sponsorship opportunities. Give your brand the awareness it deserves at the price point that works best for you.

**REGISTRATION DESK / BADGES (exclusive):** Sponsoring the registration area will increase your visibility during and after the show. Each attendee will see your name, logo and booth number as they pick up their badges and show materials before walking the show floor. **\$5,000**

## 2nd ANNUAL GSE LEADERS GOLF INVITATIONAL

The Invitational will be held on Monday March 9th, 2015 at the beautiful Revere Golf Club in Henderson Nevada overlooking the Las Vegas strip. The tournament will be a 4-person scramble with a tee off time of 12:30p.m.

**\$2,500 for 4 players**

**\$2,000 for 2 players**

**\$750\*/hole sponsor**

\*Must be a regular sponsor, hole sponsor will get an additional 2 players and signage at the hole.

**COCKTAIL RECEPTION:** Showcase your company during our high-traffic cocktail reception. Your branding creates the awareness that attendees notice, bring the client to you with bar service in your booth, complete with a banner space to highlight your business name and logo. **\$2,500/bar**

## LANYARDS (exclusive)

Be the first name attendees see by sponsoring our badge lanyards, given to all registrants.

**\$2,000 (lanyards provided by sponsor)**

## RE-USABLE WATER BOTTLES (exclusive):

Be in the hands of every Attendee when your company is the premier water bottle sponsor of the show.

**\$2,000 (bottles provided by sponsor)**

## HOSPITALITY NETWORKING BREAK:

Make a lasting impression and don't miss the opportunity to set your company apart and increase your exposure and position with our coffee and lunch networking break. **\$1,500**

## TOTE BAGS (exclusive):

Place your advertisements in the hands of every attendee by sponsoring our show bags. Your materials will be given out at each show entrance to ensure maximum exposure.

**\$1,000 (tote bags provided by sponsor)**

## FLOOR STICKER OR CARPET AISLE SQUARES:

Draw attendees to your booth with carpet decals literally underfoot on our main show floor aisles.

**\$500 for one, \$750 for two**

## METER BOARDS:

Increase your visibility beyond the confines of your booth space in the high traffic areas where attendees move about throughout the show.

**\$750/meter board**

## GROUND SUPPORT LEADERS OF THE YEAR:

Support the 2015 winners by becoming a sponsor. Three awards, Product/Service Leader, Team Leader, and Lifetime Achievement Award will be highlighted during the cocktail reception on Tuesday. Your logo will be on all materials promoting the event. **\$750**

## GSE EXPO SHOW GUIDE

(Special Digest Size)

Make your booth known among the competition! This is the official onsite guide that contains exhibitor listings, booth numbers, and the conference schedule for **GSE expo**.

**FULL PAGE..... \$2,100**

**1/2-PAGE..... \$1,350**

**LOGO..... \$300**

**AD CLOSE DATE - 1/16/2015**

**MATERIALS DUE - 1/23/2015**



# GSEexpo.com

# “WHERE DO I SIGN UP...?”

Don't be left on the outside looking in. Reserve your space for **GSE expo 2015** today!

Leading suppliers come to **GSE expo** to show off their products and services and improve their traction in the industry. Shouldn't your company be among them?

Absolutely! Don't miss out on exhibiting at **GSE expo** and its many networking opportunities.

## EXHIBIT RATES

- Standard Booths: \$25 per sq. ft.
- Perimeter Booths: \$19 per sq. ft.
- Sold

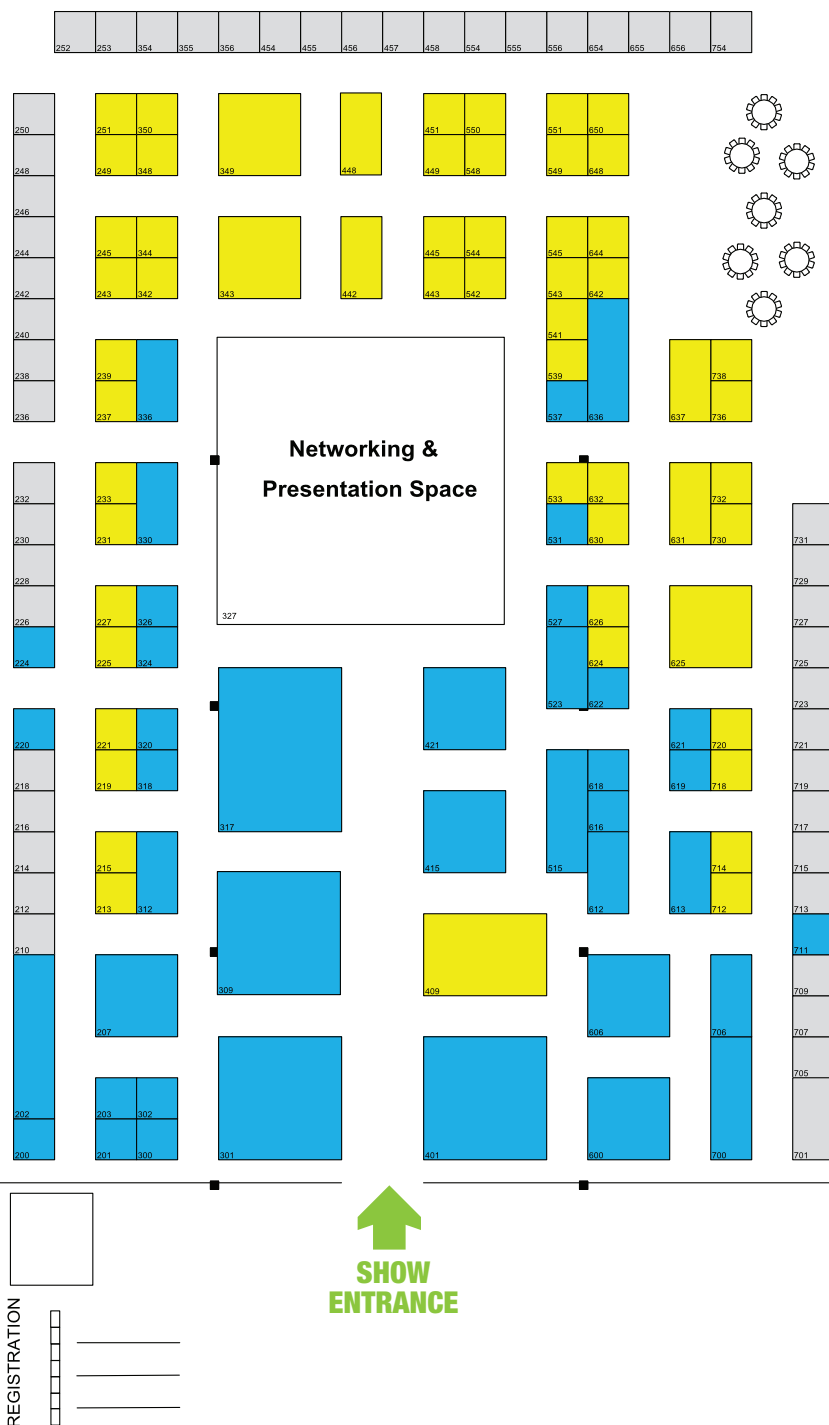

**FOR MORE INFORMATION AND TO RESERVE YOUR BOOTH, CONTACT US TODAY.**

**MICHELLE KOHN**  
National Sales Manager  
952-808-3344  
michelle@aviationpros.com

**MISSY ZINGSHEIM**  
Associate Publisher/Sales  
920-563-1665  
missy@aviationpros.com

**SUE RALSTON**  
Show Director  
920-563-1655  
sue@aviationpros.com

# YOU SPOKE, WE LISTENED

You asked for a “ground support only” event, and that’s what **GSE expo** promises to deliver. Our show is designed to maximize the opportunity for you to connect and network with your customers . . . ground support customers! With so many qualified leads in one place, **GSE expo** delivers an outstanding return on investment and the opportunity to focus on attendees that matter most.

*Presented by:*

**GROUND SUPPORT**  
WORLDWIDE

*Brought to you in part by:*

**airport**  
business



*Presented by*  
**GROUND SUPPORT**  
WORLDWIDE

## SCHEDULE AT-A-GLANCE

### SUNDAY, MARCH 8

1:00 p.m. – 5:00 p.m. Move-In  
By Appointment Only

### MONDAY, MARCH 9

8:00 a.m. – 5:00 p.m. Exhibitor Move-In

8:00 a.m. – 5:00 p.m. Registration Opens

11:00 a.m. – 7:00 p.m. 2nd Annual GSE Leaders  
Golf Invitational  
(space is limited)

### TUESDAY, MARCH 10

10:00 a.m. – 5:00 p.m. Expo Open

10:00 a.m.-11:00 a.m. Networking Coffee Break

12:00 p.m.-1:00 p.m. Lunch with Exhibitors

4:00 p.m.-5:30 p.m. Opening Night Reception  
with Ground Support  
Leaders of the Year Awards

### WEDNESDAY, MARCH 11

10:00 a.m.-3:00 p.m. Expo Open

10:00 a.m.-11:00 a.m. Networking Coffee Break

12:00 p.m.-1:00 p.m. Lunch with Exhibitors

3:00 p.m. Exhibitor Move-Out

**GSEexpo.com**

# GREEN PRODUCTS & ALTERNATIVE TECHNOLOGY

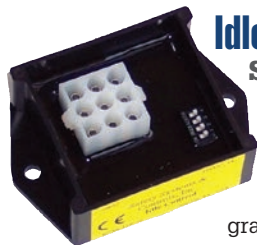

## Idle-Lok Safety Systems & Controls Inc.

Idle-Lok, a simple device to shut down an engine after user-programmable time if running idle. It can reduce idling 30-40 percent, wear and tear on equipment and maintenance. It has low temperature override for frigid conditions.

[AviationPros.com/company/10026542](http://AviationPros.com/company/10026542)



## Electric Tugs/Beltloaders Somerset Capital Partners

New electric baggage tugs and beltloaders from 12,000-pound capacity to 30,000-pound capacity. Models include eTug Lite, DC20, DC30 and the eBeltloader.

[AviationPros.com/company/10276573](http://AviationPros.com/company/10276573)

## Charger With Wireless Battery Management Minit Charger



Minit Charger introduces Altus, a smart outdoor, dual port charger with wireless battery management. It comes in four power outputs from 3.85 KW – 15.4 KW per port and works with other existing chargers regardless of the make.

[AviationPros.com/company/12012906](http://AviationPros.com/company/12012906)

## Electric Tow Tractor AERO Specialties

The Eagle Tugs eXL-16 Electric AWD/AWS Commercial Aircraft Tow Tractor features utilitarian characteristics that are unrivaled on the ramp. Capable of towing 115,000 pounds, the eXL-16 front-operated, three-seat tug features an 80V AC electric drive motor. Environmentally friendly power for all-weather towing, the eXL-16 will safely meet your towing requirements.

[AviationPros.com/company/10775848](http://AviationPros.com/company/10775848)

## Electric Towbarless Tugs Tronair Inc.

Tronair offers environmentally friendly electric towbarless tugs. Models include the JP30, JP75 and JP100 with towing capacities of 30,000 pounds, 75,000 pounds and 100,000 pounds, respectively. Move your units safely and efficiently with these rugged, compact and maneuverable units.

[AviationPros.com/company/10775871](http://AviationPros.com/company/10775871)



## TE.208 Baggage/Tow Tractor Charlotte of America

The TE.208 baggage/tow tractor is a battery-powered, four-wheel towing vehicle with enough power to provide a superior alternative to a full-size baggage tractor for those operations that don't require one. The unit is a compact highly maneuverable vehicle, which allows easy access to the operator's compartment with good front and rear visibility. A low center of gravity provides excellent stability. There are currently over 1,000 of these units operating in the field today. The unit is capable of a top running speed of 9 mph (14.4 km/h) when empty with a drawbar pull of over 1,100 lbs. (499 kg). The operator's compartment contains all the controls and indicators necessary to drive the unit including foot-operated accelerator pedal, directional lever, keyless power switch, light switch and horn switch. The battery connector is located for convenient power disconnects.

[AviationPros.com/company/12017864](http://AviationPros.com/company/12017864)



## Zero Emission GSE Harlan Global Manufacturing LLC

The Harlan Charger is zero-emission, high-power, low-maintenance and operator-friendly electric GSE. This 80V, 4,500-pound DBP electric unit is designed for the needs of today's GSE. The high-power, zero-emission Charger will meet most baggage and regional aircraft towing requirements, allowing the GSE world to remain productive.

[AviationPros.com/company/10027051](http://AviationPros.com/company/10027051)





**Lithium-Powered Tractor  
 NMC-Wollard Inc.**

Compact, maneuverable 60-hp electric AC-powered tow tractor features the highly efficient Corvus lithium ion polymer battery system. Pull capacity of the 40e is 4,000 pounds at the drawbar. Rear drive axle is planetary reduction type for efficient torque multiplication in baggage, light cargo and small to medium aircraft moving/towing applications. Short 60-inch wheelbase provides maneuverability on congested and busy tarmacs/ramps.

[AviationPros.com/company/10810927](http://AviationPros.com/company/10810927)

**Extended AP87  
 Lektro, Inc.**

Lektro recently introduced an extended version of its popular AP87 series to better handle Falcons, G-200 and Jetstar aircraft. The units have capacities up to 75,000 pounds and are priced between \$28,000 and \$45,000.

[AviationPros.com/company/10025667](http://AviationPros.com/company/10025667)



**Lithium Ion Energy Systems  
 Corvus Energy Ltd.**

High power lithium ion battery systems and retrofit kits to convert existing gas or diesel GSE to full plug-in EV. Battery engineering and support to OEM production GSE manufacturers. High power lithium backup power UPS.

[AviationPros.com/company/10817469](http://AviationPros.com/company/10817469)



**EnerSys Deserthog  
 Allen Energy**

The EnerSys Deserthog battery reduces maintenance cost by extending watering intervals up to a few months. Proven in all GSE applications, on both conventional and fast charge systems.

[AviationPros.com/company/10812402](http://AviationPros.com/company/10812402)



**NEW!**

**Freedom Hybrid • Phantom Electric • TransCon Electric**

*All come standard with the Lithium-Ion Battery Pack meaning longer run-time between charges, no maintenance and longer battery life!*



**FREEDOM**



**PHANTOM** also available in Diesel/Gas



**TRANSCON** also available in Diesel/Gas

**HARLAN also manufactures and supports Aircraft Heaters, Ground Power Units and Airstart Units. We also stock and supply a wide array of GSE and Industrial equipment parts.**



80V AC Electric/Diesel Hybrid Baggage/Cargo Tractors  
 80V AC Electric Baggage/Cargo/Pushback Tractors • 80V AC Electric Beltloaders  
 Universal Components for Fleet Commonality  
 All design work and manufacturing is done in-house at our Harlan Kansas City Factory



**The GREEN choice — the RIGHT choice**

**All Harlan Electric GSE now available with optional Lithium Ion Battery Power**

Check out our entire line of GSE equipment at [www.harlan-corp.com](http://www.harlan-corp.com)

27 Stanley Road, Kansas City, Kansas 66115, USA Tel: 913-342-5650 • 800-255-4262 • Fax 913-321-5802

[AviationPros.com/company/10017401](http://AviationPros.com/company/10017401)

# GROUND HANDLERS/ SERVICE PROVIDERS



## Refurbish/Repower GSE Hercules Engine Components

At Hercules, we can completely recycle your old belt loader, tow tractor, pushback or deicer to like-new condition for a fraction of the cost of a new piece of equipment. Our refurbishment program includes a new EPA-certified diesel or gas engine, new hydraulic pump, hydraulic hoses, dash and electrical system. Your unit will look and operate like new. We also offer a state-of-the-art electric conversion option that may pay for itself with fuel and operating cost savings.

[AviationPros.com/company/10363184](http://AviationPros.com/company/10363184)



## GSE Support Servicare G.S. Corp.

For more than 10 years we have served our customers with complete satisfaction. We have the knowledge on ground power units, loaders, air starters and other equipment to bring our customers the best service possible. We provide sales, rentals, replacement parts, safety supplies, ramp accessories, technical support and training.

[AviationPros.com/company/10817955](http://AviationPros.com/company/10817955)

## Aviation Services - ASIG

### ASIG (Aircraft Service International Group)

ASIG is one of the largest independent aviation services companies in the world with substantial operations in more than 65 cities throughout North America, Europe and Asia. For more than 55 years, the company has been providing ground handling, fueling, passenger, cargo, deicing and airport facility services to commercial airlines and airports around the globe.

[AviationPros.com/company/10024994](http://AviationPros.com/company/10024994)



## New, Used And Zero-Timed GSE Mercury GSE

Mercury GSE supplies new, used and zero-timed GSE available for purchase, rental or long-term lease. Our 30 years of ground handling and GSE experience will provide you with the facts you need to make the right decisions. We carry a varied selection of used GSE in stock at all times.

[AviationPros.com/company/10817962](http://AviationPros.com/company/10817962)



## Leasing And Financing Services

### Fortbrand Services, Inc.

Fortbrand Services has been in the business of leasing, financing, renting, maintaining and dealing in aircraft ground support and refueling equipment for more than two decades. The company uses its experience and expertise to provide tailor-made programs to meet the specific requirements of its customers.

[AviationPros.com/company/10026646](http://AviationPros.com/company/10026646)



## Service Provider

### Fraport AG Ground Services

Fraport is one of the major international ground handling providers continuously improving the global network by extending its activities world-wide. Fraport offers integrated services to customers within its growing network.

[AviationPros.com/company/10026643](http://AviationPros.com/company/10026643)

**Refurbished Lektro Equipment  
GSE Intl Inc.**

We buy, sell and refurbish U.S.-made ground support equipment. Specializing in RJ operators support equipment. Lektro towbarless tractors, Hobart 28V DC power carts, air starts, GPUs, pushback tractors, belt loaders, stair trucks, air conditioning, towbars, hydraulic mules, catering trucks, hangar power units, maintenance stands, engine stands, Hobart, Stewart & Stevenson, TLD, Trilectron, Tug Tech. FMC, JBT, Malabar, Columbus Jack, Lektro, JetPorter, NMC-WOLLARD, Lantis, Charlotte, PAR-KAN, Clyde, Wasp, Premier Deicers.



[AviationPros.com/company/10161517](http://AviationPros.com/company/10161517)

**Total Aviation Services  
Total Aviation Parts  
& Services LLC**



Celebrating 12 years of personalized service from owner operator with over 30 years experience in the GSE part business.

[AviationPros.com/company/12014123](http://AviationPros.com/company/12014123)

**Pushback/  
Tow Tractor  
Rentals  
Davin Inc.**



Davin Inc has various size pushback tractors available for long- and short-term leasing.

[AviationPros.com/company/10177563](http://AviationPros.com/company/10177563)



**Specialized Transportation  
Air Ocean Pros**

Air Ocean Pros is a specialized transportation company dedicated to the needs of the ground support industry. Extremely experienced in the handling of GSE to and from any airport or service point in the world.

[AviationPros.com/company/10812417](http://AviationPros.com/company/10812417)

**FBO Services  
Independent Fixed Base Operators Association (IFBOA)**

General Aviation Association: Our Mission ... Your Success! Offering highly rated workers comp program and many other services and products for our members.



[AviationPros.com/company/12013013](http://AviationPros.com/company/12013013)

**INTRODUCING  
THE NEXT OVERWING NOZZLE**

**The SKYHAWK 1500**  
Weighs only 5 1/4 lbs.  
100% Made in USA



- Free-Swiveling QD Spout
- All Seals Replaceable
- Not Cast, Alum. Billet
- Fits Most Interlocks
- Spout Storage Device Available
- Urethane Bumpers
- Urethane Handles
- No Plastic Poppets
- Durable Swivel
- Adjustable Closing
- Heavy Duty
- EZ To Repair
- S/S Fasteners
- Recirculation Capable
- Smooth-as-Silk Operation to 100GPM

Our unique 3-lug dust cap and Recirculation Adapter allows flow into the bottom load connector, no more climbing on top of the truck! Separate small recirculation adapter available. Custom interlock adapters available. 1 1/2" NPT or BSP, black (jet) or red (avgas).

The SkyHawk was designed based upon our 54 years in the industry to be the toughest, most durable and easiest to repair nozzle ever made. Our unique design makes recirculation safe. Try one, we think that you will agree.

**GAMMON TECHNICAL PRODUCTS, INC.**

Manasquan, NJ • <http://www.gammontech.com> • 800-524-0287

**SINCE 1960 • DISTRIBUTORS WORLD-WIDE**

[AviationPros.com/company/10017314](http://AviationPros.com/company/10017314)

## GROUND HANDLERS/SERVICE PROVIDERS



### GSE Services And Used Equipment

#### TCR International

**GSE SERVICES:** Rental and operational leasing, repair and maintenance, fleet management.

**USED GSE SUPPLY:** Large selection of motorized and non-motorized GSE, all brands. Full refurbishment is possible. Worldwide supply.

[AviationPros.com/company/11192918](http://AviationPros.com/company/11192918)

### GSE Sales, Rentals And Leasing Davin Inc.

Davin Inc. maintains a substantial inventory of late model GSE for immediate response to short-term rental requirements, and offers longer term leasing and sales of both new and used equipment.

[AviationPros.com/company/10027003](http://AviationPros.com/company/10027003)



### FleetRenu Program A&V Rebuilding, Inc.

A&V Rebuilding's "FleetRenu" program offers customers frame up remanufactured tractors for a fraction of the new cost. Engine options range from remanufactured Ford 300s to new CARB/EPA-certified Ford DSG-423 2.3L and various diesel options. All tractors are built to customer specs and come with a full manufacturer's warranty.

[AviationPros.com/company/10363034](http://AviationPros.com/company/10363034)



### Remanufactured Engines

#### JASPER Engines & Transmissions

Jasper Engines & Transmissions was founded in 1942 and remanufactures a diverse line of drive train components.

The JASPER product line includes gas and diesel engines, transmissions, differentials and diesel fuel and air system components. With nationwide inventory placement, the majority of our products are available for delivery within 48 hours – most will even be delivered the next day.

[AviationPros.com/company/10161854](http://AviationPros.com/company/10161854)



# EVOLUTION

Learning from where you've been and transforming the future forever

# PCA610

Years of reliable service

Snap-in replaceable gasket

Positive simultaneous latching

Superior air flow with protective screen

Integral spinning PCA hose connection

Contact PAGE Industries today to learn more about this phenomenal PCA Connector along with the vast array of other products PAGE Industries offers to meet your ground support needs.

PHONE

1-855-465-PAGE

1-707-469-7243

WEB

[www.pageindustries.com](http://www.pageindustries.com)

EMAIL

[sales@pageindustries.com](mailto:sales@pageindustries.com)

MAIL

2050 Cessna Drive

Vacaville, CA 95688

[AviationPros.com/company/10810746](http://AviationPros.com/company/10810746)

## GROUND HANDLERS/SERVICE PROVIDERS

### Independent Ground Handler Aviapartner

Aviapartner is one of the leading independent providers of ground handling services across 35 airports in five European countries:

- Since 1949 one of the leading European independent providers of ground handling services.
- Across 35 airports in Belgium, France, Germany, Italy and the Netherlands.
- Employs around nearly 6000 staff serving needs of 30 million passengers.
- A wide range of services to over 400 passenger and cargo airlines.
- Ramp handling for 300,000 aircraft movements.
- Cargo handling for around 1 million tons of cargo each year.
- IT capabilities, enabling us to deliver unparalleled service quality and flexibility according to the needs of each airline.
- Supported by numerous quality certifications and airline awards.



[AviationPros.com/company/10024992](http://AviationPros.com/company/10024992)



### Ground Handling Services Swissport International Ltd.

Swissport International Ltd. provides ground services for around 224 million passengers and 4.1 million tonnes of cargo a year on behalf of some 700 client-companies in the aviation sector. With its workforce of around 55,000 personnel, Swissport is active at 266 airports in 45 countries on five continents and generates consolidated operating revenue of \$3.1 billion.

[AviationPros.com/company/10025374](http://AviationPros.com/company/10025374)



### Ground Handling Logistics Equity Aviation Services (Pty) Ltd.

We specialize in passenger, ramp and cargo handling services. Currently we handle in excess of 20 000 aircraft movements per month and offer ancillary services such as Aircraft Washing and VIP Meet and Assist. We also have an accredited Airside Service Centre and training academy.

[AviationPros.com/company/10026477](http://AviationPros.com/company/10026477)

### Xcēd Aviation Services

#### Xcēd Aviation Services - Sasser Family Holdings Company

Sasser Family Holdings, Inc. is pleased to announce the opening of our aviation ground support equipment finance and asset management subsidiary; Xcēd Aviation Services, LLC. Xcēd will be providing single investor equipment financing solutions and life cycle management of all aviation ground support equipment for North America. We look forward to delivering end-to-end aviation ground support equipment financing and asset management solutions that will truly exceed your expectations.



[AviationPros.com/company/12014721](http://AviationPros.com/company/12014721)

Meet us in Dubai and Singapore



Dec 08-10 2014  
Dubai - Booth# 432

Jan 21-23 2015  
Singapore - Booth# B10

Advantage Mototok:

# MORE SPACE – BETTER HANDLING

for your Operations.

10+ Years  
of  
German  
Engineering  
and Quality.



The ability to move a wide range of aircraft types becomes an ease with Mototok. Depending on the nose wheel size and the gross weight of the aircraft, you can choose one of 4 Mototok models. Regardless the size of the aircraft – Mototok excels in narrow situations: Park your aircraft safely, easily and effectively and save space in the process.

We offer units that work with the following weights:

Model	M 528	TWIN 6500	SPACER 8600	SPACER 195
Towing capacity	28 t 61,700 lbs	50 t 110,200 lbs	95 t 209,400 lbs	195 t 429,900 lbs



Want to know, how it works?  
Watch the video on  
[www.mototok.com/space](http://www.mototok.com/space)

Innovative  
remote controlled  
electric driven tugs

# mototok®

easy moving

Mototok America LLC  
3028 Peacekeeper Way  
McClellan, CA 95852 / USA  
Phone: +1-916-580-4977  
Fax: +1-916-641-8969

Mototok International GmbH  
Hohenzollerstr. 47  
D-47799 Krefeld / Germany  
Phone: +49-2151-65083-82  
Fax: +49-2151-624-673

[info@mototok.com](mailto:info@mototok.com) • [www.mototok.com](http://www.mototok.com)

[AviationPros.com/company/11326680](http://AviationPros.com/company/11326680)

# LAV/POTABLE WATER CARTS & ACCESSORIES



## Vacuum Lavatory Service Truck

**Accessair Systems Inc.**

New features: An automated control system, based on preset quantities, whereby the selection of the aircraft type by the operator allows the aircraft to be serviced automatically. For enhanced record keeping, a Data Logger is also available allowing the retrieval and storage of data via WiFi, USB, etc.

[AviationPros.com/company/10027590](http://AviationPros.com/company/10027590)

## Lav and Water Carts AERO Specialties

AERO Specialties has designed a new series of lav and water carts for regional airlines and busy FBOs. In response to requests from regional airline customers, the new carts are built to exceed regionals' rigorous standards for ramp equipment durability. The LC60-RJ Lavatory Service and WC60-RJ Potable Water Service carts share the same 4,000-pound capacity rust-proof chassis and insulated tank enclosure system, as well as winterization and electric pump system. AERO's RJ series lavatory and water carts continue to be in strong demand around the globe.

[AviationPros.com/company/10025317](http://AviationPros.com/company/10025317)

## Lav Hose

**Hi-Tech Duravent**

The Hi-Tech Duravent Lav Hose is designed to withstand the rugged conditions of an airport ramp. This industry tested, durable urethane hose is thermally bonded with nylon helix, and is abrasion, crush and kink resistant. It is translucent blue with smooth interior walls and durable blue cuffs.

[AviationPros.com/company/10027375](http://AviationPros.com/company/10027375)



## Lavatory Service Truck Phoenix Metal Products

Phoenix lavatory service trucks have stainless steel tanks and module. Standard module is a brushed finished stainless steel that requires no painting. This will reduce years of repainting cost and presents a sanitary appearance. Features include waste hose storage tray and a waste inlet swivel.

[AviationPros.com/company/10027042](http://AviationPros.com/company/10027042)

# GROUND POWER

FOR UNBEATABLE GROUND POWER UNITS...

- 2400 peak amps
- 71 lbs/32 kg complete
- Built-in chargers
- 28.5v continuous
- AC Input: 110v or 220v



- Diesel-powered Hi-Brd GPU 28.5VDC
- 300 amps at 28.5VDC
- 3500 peak amps

...THERE IS NO SUBSTITUTE!

**WWW.STARTPAC.COM**

OR CALL TOLL FREE 888.901.9987



[AviationPros.com/company/10135102](http://AviationPros.com/company/10135102)



**Lav Truck**  
**NMC-Wollard Inc.**

Lavatory service truck (Model 770) features F-350 chassis, 400-gallon waste capacity, 11-gallon stainless steel tank. Potable water truck (Model 402) features F-350 chassis and 450-gallon capacity stainless steel tank.

[AviationPros.com/company/10810934](http://AviationPros.com/company/10810934)

**Reconnectable Potable Water and Lavatory Service Breakaway Couplings**

**AIRLINX Aircraft Services Inc.**

Breakaway couplings are available for potable water and lavatory service applications. The reconnectable design does not require any replaceable



parts upon disengagement. After a mishap, it can be reconnected within seconds on the ramp,

ensuring there is no downtime in servicing aircraft.

[AviationPros.com/company/10026850](http://AviationPros.com/company/10026850)



**Potable Water Truck**  
**Stinar Corporation**

The SPW-350PL Potable Water Truck has a 500-gallon water tank capacity. We also offer models with 600-, 700- and 1,000-gallon capacities

[AviationPros.com/company/10025864](http://AviationPros.com/company/10025864)

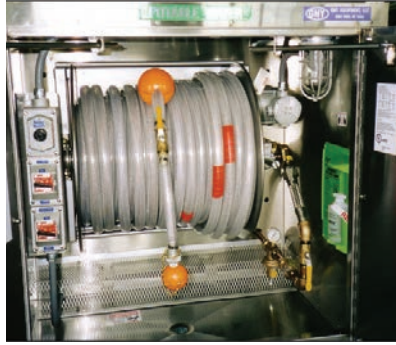

**Potable Water Cabinets**  
**GNY Equipment LLC**

GNY Equipment's Potable Water Cabinets are UL-listed units that expedite dispensing of potable water to aircraft in congested loading locations through 200 ft. + hoses. Cabinets are double wall, insulated and heated stainless steel with two large doors. Can be mounted or flush through terminal wall, also on pedestal of loading-bridge or be free standing.

[AviationPros.com/company/10026291](http://AviationPros.com/company/10026291)



**Purogene Aircraft Sanitation System**  
**AeroSafe Products Inc.**

P.A.S.S. Purogene Aircraft Sanitation System from Aerosafe disinfects and sanitizes aircraft water systems in minutes. Used for general aviation, corporate and commercial aviation and marinas. Available as roll round, full water cabinets or retrofit models. All stainless steel construction.

[AviationPros.com/company/10026365](http://AviationPros.com/company/10026365)

**Eliminate Ramp Damage**  
 with Wireless Headset Solutions

Portable wireless headset system



*pushback | maintenance | deicing | aircraft movement | cargo*

More than 4,000 times per day, Flightcom wireless headset systems prove their performance and reliability at many of the world's busiest airports. Discover how you can eliminate ramp damage and increase safety.

**FLIGHTCOM**  
 Wired and Wireless Headsets

800.432.4342  
[sales@flightcom.net](mailto:sales@flightcom.net)  
[www.flightcom.net/wireless](http://www.flightcom.net/wireless)

[AviationPros.com/company/10017282](http://AviationPros.com/company/10017282)

# MAINTENANCE & SHOP EQUIPMENT



## Portable Electric Driven Gas Booster Hydraulics International Inc.

Hydraulics International, Inc.'s portable Electric Driven Gas booster is rated to 10,000-psi for breathing air/N2 and 4,500-psi for oxygen service. Ideal for filling or topping off cylinders, tires, accumulators, struts, and life rafts. Its two-stage and double acting design uses no belts or pulleys, making it the quietest electrically operated booster in its class at only 60 decibels.

[AviationPros.com/company/10027134](http://AviationPros.com/company/10027134)

## Seat Solutions Concentric International

Concentric builds seats to strict tolerances to help ensure a correct fit for your application. High durability and ergonomic designs maximize user comfort, which can increase productivity and efficiency in all applications.



[AviationPros.com/company/12012918](http://AviationPros.com/company/12012918)

## Tier IV Solution Engine Distributors Inc.



Featuring a complete line of EPA- and CARB-certified 1.5, 2.3, 4.0 and 6.8 LSI engines ranging from 20 to 200 horsepower. Available in gasoline, LPG, CNG, natural gas and dual fuel. Our engines are the solution to high-

priced Tier IV diesels.

[AviationPros.com/company/10442466](http://AviationPros.com/company/10442466)

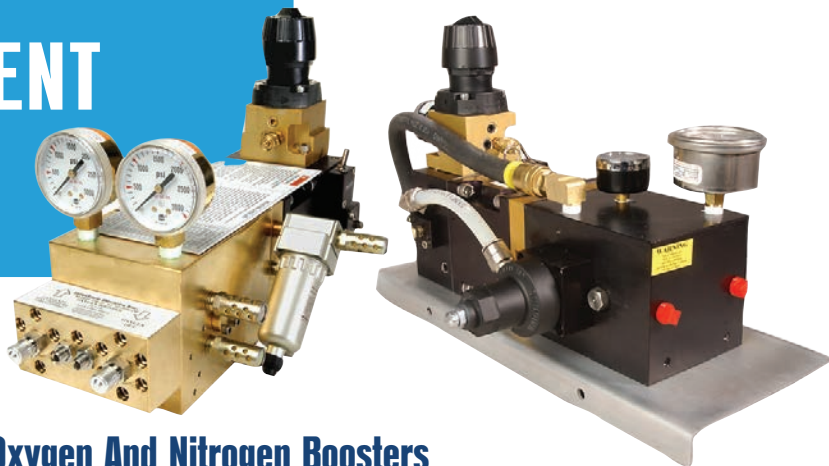

## Oxygen And Nitrogen Boosters Taughanock Aviation Corp. - Ground Support Equipment

The oxygen and nitrogen boosters are used to boost low-pressure bottles to higher specified pressures. This allows greater utilization of low-pressure bottles, thus lowering the number of cylinders kept in inventory and significantly decreasing the amount of wasted oxygen and nitrogen.

[AviationPros.com/company/10027274](http://AviationPros.com/company/10027274)

## Engine Compressor Wash Rig A.T. Juniper (Liverpool), Ltd.

The 2x25 gallon engine compressor washing rig is the mainstay of the Juniper range. Versatile enough to tackle most engines when partnered with our growing list of wash probes, lances and spray rings, yet maneuverable enough for the most remote areas of an airfield.

[AviationPros.com/company/10027072](http://AviationPros.com/company/10027072)



## Maintenance Hoists PF Fishpole Hoists Inc.

PF Fishpole hoists are precision-engineered aircraft equipment maintenance hoists for single attach point equipment installation and removal on all commercial aircraft:

- Valve engineered products.
- Short lead times.
- Speedy service at many locations worldwide.

[AviationPros.com/company/10441302](http://AviationPros.com/company/10441302)



## Tilttable Carts Tronair Inc.



Tronair's new four-cylinder tilttable carts meet OSHA/EU-OSHA safety requirements for one-person cylinder lifting. The carts feature an "operator assistance system" that eases the movement of cylinders from vertical to horizontal.

[AviationPros.com/company/11193215](http://AviationPros.com/company/11193215)

## Oxygen And Nitrogen Boost Pumps American Airworks

Ground and maintenance service oxygen and nitrogen gas boost pumps, pneumatic and electric-powered for aircraft cylinder refilling, strut pressurization. We sell and service Haskel boosters and electric gas boosters.

[AviationPros.com/company/12013018](http://AviationPros.com/company/12013018)



## Fuel Fume Exhaust Systems

### Precision Air Solutions LLC

MAX 1 Fuel Fume Exhaust Systems for aircraft parked inside the MRO facility to enhance employee safety with dramatically increased production.

[AviationPros.com/company/12012987](http://AviationPros.com/company/12012987)



## One-Person Wheel Change ColumbusJACK/Regent

The Wheel & Brake Dolly is used worldwide by most major airlines, making wheel changes a one-person operation. It is a portable self-contained unit capable of handling and transporting either a wheel/tire or brake assembly during the removal from or installation on an aircraft.

[AviationPros.com/company/11195549](http://AviationPros.com/company/11195549)



## Towable Fluid Carts US Mfg. & Design Inc.

Towable fluid servicing cart (Patent number 29/358,421) used for servicing an aircraft hydraulic or engine oil system reservoir. The cart is designed for use as a general-purpose fluid servicing of CSD/IDG, engine oil and hydraulic reservoirs and is used mainly for topping off the system. It also has an over flow container attached for fill and bleed servicing.

[AviationPros.com/company/10876260](http://AviationPros.com/company/10876260)



## 'Fly Away' Jacks

### Malabar International

Malabar's 35- to 95-ton "fly-away" axle jacks are readily air transportable. The line includes 35-ton Model 8782, 45-ton Model 8919, 65-ton Model 8714 and 95-ton Model 8920. Compact design includes two manual hand pumps (one high pressure - low volume and one low pressure - high volume); the extension screw and hand pump parts are plated to resist corrosion; Skydrol-resistant paint; and one-year warranty. A floating cylinder assembly is available on Model 8920. All have dual manual and air-operated pumps and chrome-plated cylinder and plunger bores.

[AviationPros.com/company/10762758](http://AviationPros.com/company/10762758)



## Hydraulic Lifts Stertil-Koni

Stertil-Koni, is recognized as a global market leader in heavy-duty hydraulic lifts and is the preferred supplier to the world's leading companies in the truck and bus industries. Its breadth of products meets all ranges of lifting needs and includes mobile, two-post, four-post, parallelogram lifts, half-scissors, and the innovative axle-engaging, in-ground, scissor lift configuration. It has recently introduced DIAMOND LIFT, a full rise telescopic piston lift designed to set new standards in precision heavy-duty lifting performance, durability, ease of use, and environmental containment.

[AviationPros.com/company/10825801](http://AviationPros.com/company/10825801)

## ContiRV20 Continental Tire

The ContiRV20 is the first industrial tire developed specifically for aviation ground support equipment. Featuring dual-steel belt construction, reinforced side-walls, low rolling resistance and low heat generation, the ContiRV20 has reduced one major airline's tire replacement and maintenance by more than 80 percent.

[AviationPros.com/company/10441013](http://AviationPros.com/company/10441013)



## Axles And Components Taylor-Dunn Manufacturing

Metro Crown International is a premier supplier of front steer axles and components to fit most major brands of baggage tractors. MCI manufactures and stocks the components parts and can turn many orders around the same day at a significant cost savings to our customers.

[AviationPros.com/company/10441757](http://AviationPros.com/company/10441757)

## Gas Boosters and Systems MAXPRO Technologies Inc.



Oxygen and Nitrogen gas boosters and systems for filling and topping off on-board oxygen bottles and nitrogen filling of tires. Enables better utilization of low-pressure bottles, decreasing the amount of oxygen and nitrogen wasted.

[AviationPros.com/company/11486737](http://AviationPros.com/company/11486737)

## MAINTENANCE & SHOP EQUIPMENT



### Heavy-duty Hose Reel Hannay Reels Inc.

Hannay Reels 6000 Series manual or power rewind heavy-duty hose reel is designed for aviation applications, including portable water transfer, hangar operations and fire protection. With a durable construction and finish, this series can stand up to any environment. Handling 1/2-inch through 1-inch I.D. hose, the 6000 Series crank rewind reel is supplied with a pinion brake, while a power rewind reel includes a comet brake. Its standard inlet is equipped with a 90-degree ball-bearing swivel joint with 1-inch female NPT threads and the standard outlet with 1-inch female NPT threads, which are all constructed from steel. This model accommodates pressures up to 2,000 psi and temperatures from 60 F to +250 F (-51 C to +121 C).

[AviationPros.com/company/11362703](http://AviationPros.com/company/11362703)



### Explosion-Proof Lighting ATI - Advanced Technologies Inc.

Explosion-proof portable lighting equipment for hazardous and confined space areas. Ideal for fuel cell inspection and maintenance. Brilliant white light at 5,700 (K) degrees color temp, 3,100 Lumens emitted via fiber optic cables. Internationally certified for Class 1, Div. 1, Group C and D hazardous environments.

[AviationPros.com/company/10441001](http://AviationPros.com/company/10441001)

### Spiral Box Stairs Wasp Inc.

WASP builds OSHA- and CE-recommended safety features into its stairs to minimize risk and liability. In addition, the company forms the main frames for its staircases with tubular steel for optimal stability and capacities of 1,000 pounds (454 kilograms) or more, as required. Grip Strut™ steps and platforms provide maximum slip protection for additional safety. The stairs also are equipped with towbar-actuated brakes. Beyond crew safety, the staircases feature durable lead-edge rubber bumpers to protect aircraft from damage. WASP also uses premium casters with a 10-inch-diameter (0.25-meter) swivel and 10-ply pneumatic tires for easy maneuverability and long-lasting service. These features, as well as premium components, boost the durability of the product and guarantee long life. Spiral Box Stairs are available in fixed or adjustable height options. The fixed model features a height of 185 inches (4.7 meters) and the adjustable height provides a range of 171 to 195 inches (4.3 to 5 meters) for flexibility with a variety of aircraft.



[AviationPros.com/company/11678953](http://AviationPros.com/company/11678953)

### Scissor Lifts Man Lift Mfg. Co.

Explosion Proof (EX) equipment is becoming standard for companies who want to increase productivity while working safely in Class 1 Division 1 Group D hazardous environments such as paint booths.

Man Lift offers scissor lifts with working heights from 21 to 56 feet and platform capacity from 500 to 2,000 pounds. Machines include extension decks from 3 to 5 feet. They feature smooth proportional hydraulic controls and are electric-powered.



[AviationPros.com/company/12008756](http://AviationPros.com/company/12008756)



Hydraulics International, Inc.  
**OXYGEN & NITROGEN SYSTEMS**

## INCREASE SYSTEM REFILL CAPACITY UP TO 50% AND ELIMINATE CASCADING

Primary use for filling or topping off...

- Onboard Oxygen Bottle
- Underwater Breathing Apparatus (UBA)
- High Altitude High Opening (HAHO)
- Tires
- Accumulators
- Struts
- Escape Chute
- Life Rafts

Even if your cascade system pressure drops below 200-psi

#### ELECTRIC DRIVEN SERIES 2G

Weight: 145-LBS  
Dimensions: 32"L x 11.5"H x 20"D  
Noise Level: 60-dBa  
Double acting or 2-stage design uses no belts or pulleys



#### PNEUMATIC DRIVEN SERIES HIHPG3

Weight: 40-LBS  
Dimensions: 20"L x 12.5"H x 11.5"D  
Noise Level: 78-dBa



#### Hydraulics International, Inc.

9201 Independence Ave., Chatsworth, CA 91311 USA  
(Phone) 818.407.3400 | (Fax) 818.407.3428

[www.hiigroup.com](http://www.hiigroup.com)

HYD-3331

[AviationPros.com/company/10017435](http://AviationPros.com/company/10017435)



**Telescopic Boom Lift**  
**JLG Industries Inc.**

The JLG 1500SJ telescopic boom lift handles dual 1,000/500-pound loads and provides immediate access to work at elevated heights by lifting operators 150 feet. A 25-foot telescoping jib offers work envelope flexibility and additional outreach at elevation. Equipped with a fuel-efficient Tier 4 engine, the 1500SJ features three steering modes and exceptional terrainability. The boom is also easy to transport from one location to another, thanks to a design that requires only a weight permit for highway transport in the United States.

[AviationPros.com/company/11598724](http://AviationPros.com/company/11598724)

**Measurement & Test**  
**Equipment Specialists**  
**Calibration Specialty Inc.**



Calibration Specialty Inc. understands the customer and the equipment. We don't charge outrageous evaluation fees just to tell you what you already know. We have the ability to repair and

we let you know cost up front before any work is done.

[AviationPros.com/company/10817972](http://AviationPros.com/company/10817972)

**Maintenance Stand**  
**Clyde Machines Inc.**

Maintenance Stand features non-slip, self-cleaning steps and platform floor with a 500-pound capacity. Heavy-duty casters and 16-inch solid tires make it easy to move. Upper-platform railings can be lifted out and store below. Mid-platform railings can be easily swung down and out of the way. Platform heights are 57, 75 and 86 inches.

[AviationPros.com/company/10895715](http://AviationPros.com/company/10895715)



**New Heavy-Duty e-Hitch**  
**SAF-Holland**

The new EH-HD features a heavy-duty design with up to 22,680 kg (50,000 pounds) MDBP with an increased vertical load rating of 454 kg (1,000 pounds). Unique to the EH-HD is its large, bolt-on mounting flange that can accommodate and be customized for multiple bolt patterns and bolt-hole sizes, including metric and SAE dimensions. The versatility in mounting provides airlines and ground service providers the opportunity to standardize hitch specifications and retrofit across their entire fleet of tugs, carts, and dollies. The EH-HD mounting flange is also approved for weld-on mounting.

[AviationPros.com/company/11308556](http://AviationPros.com/company/11308556)



**GAS BOOSTERS**  
*Your DIRECT SOURCE in North America*  
*for Oxygen or Nitrogen Service Boosters*



[www.MaxProTech.com](http://www.MaxProTech.com)

*Maximator Gas Boosters and*  
**MAXPRO Gas Booster Packaged**  
*Power Systems are available for your*  
**Ground Support needs!**





*We also offer IN HOUSE*  
**cleaning for Oxygen Service**

**THE MAXPRO**  
 COMPANIES  
 7728 Klier Dr. S,  
 Fairview, PA 16415

[AviationPros.com/company/10017578](http://AviationPros.com/company/10017578)

# PASSENGER STAIRS/ LIFTS/BOARDING BRIDGES

## A-380 Passenger Lift

### Ground Support Specialist LLC

The GS260 is an electrically powered disabled passenger lift that will service aircraft up to the A-380. This proven and simple design allows for single-person operation. These highly reliable units have an excellent track record and require minimal maintenance.



[AviationPros.com/company/10222703](http://AviationPros.com/company/10222703)



## Towable Passenger Stairs

### Wasp Inc.

WASP's Towable Passenger Stairs include models for regional aircraft (62-96 inch sill height), narrow-body aircraft (86-134 inch sill height), wide body aircraft (132-160 inch sill height). Features Morton® non-slip surfaces; 12V timed lighting; ready-to-use towbar, movable by hand; moveable platform handrails; auto-locking deck stabilizer; hydraulic stair stabilizer; and optional canopy.

[AviationPros.com/company/10026635](http://AviationPros.com/company/10026635)

## Boarding Bridge Contact Detection

### Tapeswitch Corporation

Tapeswitch Corporation is the leading manufacturer of safety edges for contact detection applications and passenger boarding bridges.

[www.tapeswitch.com](http://www.tapeswitch.com)



[AviationPros.com/company/10441788](http://AviationPros.com/company/10441788)



## Truck-Mounted Passenger Stair

### Phoenix Metal Products

Phoenix Metal Products, Inc. has added a new passenger stair to complete its full line of stairs. Available now is the model PNX-PAS228 Truck-Mounted Passenger Stair with a door sill height from 96 inches down to 228 inches up. The chassis is a Ford F450 SD with six stabilizers.

[AviationPros.com/company/10219299](http://AviationPros.com/company/10219299)



## Radial Boarding Bridges

### Ameribridge LLC

Ameribridge provides new radial boarding bridges for the commuter aircraft operations market. Ameribridge acquired all rights to the Dewbridge product line in 2012, and is now taking the radial boarding bridge to an even higher level of service and reliability. Several design, engineering and component enhancements keep the new Ameribridge radial boarding bridge at the top of the aviation industry's list for safety, security and comfort in serving customers on commuter aircraft.

[AviationPros.com/company/10976888](http://AviationPros.com/company/10976888)



## Passenger Boarding Ramp

### Keith Consolidated Industries

The BAR Ramp is a universal ramp designed to serve larger sized aircraft such as the MD80 up to the 757. The ramp allows for a seamless boarding process for all passengers.

[AviationPros.com/company/10027352](http://AviationPros.com/company/10027352)



## Boarding Bridge Repair And Maintenance

### Oxford Airport Technical Services

Boarding bridge repair and maintenance services for airports and airlines is available from Oxford Airport Technical Services

[AviationPros.com/company/10133223](http://AviationPros.com/company/10133223)

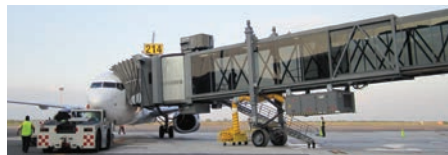

**Regional Aircraft Bridge**  
**JBT AeroTech,**  
**Jetway Systems**

The JETWAY® TeleRadial Regional Bridge from JBT AeroTech, Jetway Systems®, is part of a complete line of regional aircraft solutions that include fully integrated preconditioned air, ground power, and provides improved safety and convenience for passengers, service staff and the aircraft itself. The longest expected life and lowest life-cycle cost of any bridge available, and the flexibility to handle all aircraft from Dash 8 through B757.

[AviationPros.com/company/10024665](http://AviationPros.com/company/10024665)



**Passenger Stairs/**  
**Specialized Chassis**  
**SCHOPF Maschinenbau**  
**GmbH**

SCHOPF PS 560 A/B is based on a specially developed airport vehicle chassis to service aircraft with door sill heights between 1.9 and 5.8 meters, powered by a diesel engine with hydrostatic drive. Also available as VVIP/VIP version. Options include all-weather-canopy, sun roof, auto-leveling system, etc. SCHOPF stairs are in service at civil airports worldwide and with military forces in various countries.

[AviationPros.com/company/10025049](http://AviationPros.com/company/10025049)



**Multiple Wheelchair Lift**  
**Lift-A-Loft Corporation**

The Lift-A-Loft WBDPL provides an efficient and safe means of boarding and de-boarding passengers that require special assistance. The WBDPL can interface wide body aircraft such as Boeing 747, 767 and 777, as well as narrow body and regional jets. The unit can accommodate up to three full-sized wheel chairs and one attendant at one time.

[AviationPros.com/company/10027162](http://AviationPros.com/company/10027162)



**Bridges For Passengers**  
**With Reduced Mobility**  
**Aviramp**

Aviramp replaces traditional airstairs with a ramp and enables passengers with reduced mobility to board aircraft without having to be loaded by hydraulic lifts or carried up the stairs.

[AviationPros.com/company/10226261](http://AviationPros.com/company/10226261)



**A380 Boarding Bridge**  
**ThyssenKrupp**  
**Airport Systems**

ThyssenKrupp Airport Systems Inc. manufactures state-of-the-art A380 Passenger Boarding Bridges. The ThyssenKrupp solution applies two, or more, bridges at the lower and upper decks to service doors L1/L2 and U1. The A380 bridge is available in steel or glass.

[AviationPros.com/company/10025952](http://AviationPros.com/company/10025952)

**We Lead the Industry in Innovation**

**New!** Orion Deicer  
880 gallons  
47 Foot working height  
10 minute heat time

**New!** GRV Glycol Recovery Vehicle  
750, 1300, 2100 gallon options

Learn about the latest from Global Ground Support, and how these new products save you time and money.

**New!** 2200 XR 57 Foot working height  
NO stabilizers

**Training Simulator - Deicing**  
Grades Students on Performance

**GLOBAL**  
GROUND SUPPORT  
An AirT Company

540 East 56 HWY  
Olathe, KS 66061-4640 USA  
(913) 780-0300 [www.globalgroundsupport.com](http://www.globalgroundsupport.com)

ISO 9001:2008-certified quality management system

[AviationPros.com/company/10017340](http://AviationPros.com/company/10017340)

# PUSHBACKS/ TRACTORS/UTILITY VEHICLES



## Hybrid Tractor Harlan Global Manufacturing LLC

Harlan Global Manufacturing presents its cutting edge hybrid tractor. The Harlan Hybrid HTH is manufactured with modular components. This means the diesel engine can easily be replaced with LPG, CNG, fuel cell or any other emerging technology.

[AviationPros.com/company/10026177](http://AviationPros.com/company/10026177)



## Pushback Tractor Eagle Tugs

Introducing the new XL-series pushback tractors from Eagle Tugs, featuring standard 4WD/4WS for superior control of all narrow-body aircraft, in all weather conditions. The XL-series are backed by an industry-leading 3-year/3,000-hour warranty.

[AviationPros.com/company/11191687](http://AviationPros.com/company/11191687)



## Electric Towing Vehicles Lektro, Inc.

LEKTRO is the global leader in electric, towbarless aircraft towing vehicles. Their patented universal cradle gently lifts the nose gear and allows for unparalleled towing maneuverability. LEKTRO invented the first towbarless towing vehicle in 1967 and continues to pioneer leading technologies for safer, more efficient aircraft towing. Their all-electric towing vehicles come in five different model series that can handle aircraft ranging from the smallest piston aircraft to narrow body airliners like the Boeing 737 and Airbus A321.

[AviationPros.com/company/10026038](http://AviationPros.com/company/10026038)



## Softcapture Cradle Tronair Inc.

Tronair's JP100SSC SOFTCAPTURE® TLTV is equipped with the SOFTCAPTURE® cradle that allows the tug operator to capture aircraft from the driver's seat without the use of straps on the strut or the nose landing gear.

[AviationPros.com/company/11193210](http://AviationPros.com/company/11193210)

## Maneuverable Tugs Mototok America LLC

More Safety, More Space, More Revenue! 100 percent visual control around the aircraft. No knocks. No collisions. No towbars. And optimum use of limited space! Only Mototok aircraft tugs are capable of maneuvering a plane's nose a few millimeters away from a hangar wall and, above all, quickly and efficiently prepare all other aircraft or helicopters in the hangar for their next duties.

[AviationPros.com/company/11706293](http://AviationPros.com/company/11706293)



## Electric Pushback JBT AeroTech, Jetway Systems

The JBT AeroTech B400e electric pushback tractor is designed to handle all RJ's and narrow-body aircraft, including the B757. Outstanding features include an 80-volt AC electrical system, single maintenance free motor and controller, and a rear-mounted 930 Ah battery providing two shifts worth of pushbacks before recharging.

[AviationPros.com/company/10027424](http://AviationPros.com/company/10027424)

FOR MORE PRODUCTS VISIT  
**AviationPros.com**



## CT5G Baggage Tractor Charlotte of America

The CT5G comes with a choice of two gas engines - either a Ford four-cylinder, 2.5-liter engine or a four-cylinder, 2.8-liter engine from Zenith Power Products LLC - or a Deutz diesel engine. A Paillard axle is in front and an AxleTech axle in back.

[AviationPros.com/company/10818003](http://AviationPros.com/company/10818003)



## Douglas Aircraft Towing Tractors Douglas Equipment Ltd.

A complete range of towbarless and conventional aircraft towing tractors for handling all aircraft up to and including the A380, offering airlines and ground handling companies significant opportunities to reduce their operational costs and improve their operational efficiency.

[AviationPros.com/company/10026898](http://AviationPros.com/company/10026898)

## Towbarless Tractors Goldhofer Aktiengesellschaft

The Goldhofer AST-1 X 490 and AST-1 X 680 represent the innovative upgrade of the proven AST-1 F/L aircraft tractor by extending the aircraft range up to the B747-8 and A380. The tractors tow aircraft up to 1,32 million pounds. Engine output is 490 PS or 680 PS. Max. NLG load: 108,000 pound-feet.



[AviationPros.com/company/10227022](http://AviationPros.com/company/10227022)

# WE HAVE STAIRS

FROM RJ TO A340 CHASSIS MOUNTED AND TOWABLE



PNX-CMPPS96/150  
NARROW BODY STAIR



ALSO:  
LAVATORY AND WATER SERVICE  
CARTS & TRUCKS  
MAINTENANCE LIFTS  
BELT LOADERS



3000 INDUSTRIAL AVENUE 3  
FT. PIERCE, FL 34946  
PHONE: (772) 595-6386 / FAX: (772) 595-6389  
EMAIL: [phoenixgse@earthlink.net](mailto:phoenixgse@earthlink.net)  
WEBSITE: [www.phoenixgse.com](http://www.phoenixgse.com)

[AviationPros.com/company/10017661](http://AviationPros.com/company/10017661)

# What a turn-on!

Discover the clean power  
of Eagle electric tugs



Effortlessly handle aircraft up to 165,000 lbs. with Eagle Tug's innovative eXL-16 and eTT series electric tugs! All-wheel drive, precision 4-wheel steering, vehicle inching controls at both hitches and seating for three. 



+1 208-378-9888 | [www.aerospecialties.com](http://www.aerospecialties.com) 

[AviationPros.com/company/10016920](http://AviationPros.com/company/10016920)

## PUSHBACKS/TRACTORS/UTILITY VEHICLES



### Extended Towing Tractor Bliss-Fox Ground Support Equipment

The Bliss-Fox F1-150 aircraft pushback and extended towing tractor is designed in Australia for both pushback and extended towing of fully laden aircraft from 110-182 tons. This tractor suits pushback and towing on A321 and B737 aircraft. With power to spare, the all-new F1-150 features a 138-hp diesel engine with 125.6kN of draw bar pull. This modern styled, unique tractor is available as a standard 11-ton base model with options for air-conditioning and ballast up to 18 tons of total tractor mass.

[AviationPros.com/company/10363230](http://AviationPros.com/company/10363230)

### Traditional Pushback Tractors

#### TLD

TLD has been manufacturing GSE for more than 50 years. Manufacturing tractors capable of serving regional jet to super jumbo jets, TLD has a tractor to serve any market. Featuring a variety of different configurations and options, TLD can make a tractor that will thrive in even the most challenging ramp conditions.

[AviationPros.com/company/10363123](http://AviationPros.com/company/10363123)



### Alternative Drive Technology

#### MULAG Fahrzeugwerk GmbH u. Co. KG

The MULAG GSE product range offers the customer a good choice of innovative concepts, such as hybrid drives, LPG or CNG drives and fuel cell drives that are all suitable for reliable application on the apron and provide just the edge of technology advantage that is needed for a future-oriented ground handling concept.

[AviationPros.com/company/10756699](http://AviationPros.com/company/10756699)



"Simply the best hoists for every aircraft."

- Boeing
- Airbus
- Fokker
- DeHavilland
- Bombardier
- Embraer
- US Air Force

**PF FISHPOLE HOISTS**  
SALES • SERVICE

1505 S. 93rd St, Unit BL, Seattle, WA 98106 USA  
206.767.3887 • Fax 206.767.4006 • [pffishpolehoists.com](http://pffishpolehoists.com)

[AviationPros.com/company/10017652](http://AviationPros.com/company/10017652)

### CHALLENGER 700

#### Trepel Airport Equipment GmbH

The CHALLENGER 700 is a conventional aircraft tractor that is capable to handle push-back, repositioning and maintenance towing of all wide body aircraft including a fully loaded Airbus A380. The mechanical lock-up clutch of the new generation of power shift transmission reduces fuel consumption when moving at higher speed. The liftable power-pack compartment minimizes downtime of the tractor and reduces maintenance costs.

[AviationPros.com/company/10177176](http://AviationPros.com/company/10177176)



### GSE Specialist

#### Carolina GSE Inc.

We are a distributor for JetPorter electric aircraft tugs, including the JP30/JP30L (tow up to 30,000 lbs) and the JP100s (tow up to 100,000 lbs).

[AviationPros.com/company/12012893](http://AviationPros.com/company/12012893)



## PUSHBACKS/TRACTORS/UTILITY VEHICLES

### All-Purpose Vehicle Lift-A-Loft Corporation

The Lift-A-Loft APV (All-Purpose Vehicle) is designed to withstand the demands of a hectic ramp environment. The APV can be configured in several different versions, such as high speed tow, lavatory/potable water, maintenance lift, catering truck, crew van, ambulatory lift and many more applications.



[AviationPros.com/company/10027483](http://AviationPros.com/company/10027483)

### Low-profile Tractor

#### Trowin Industries Inc.

The Mark III low-profile tractor offers ergonomic superiority and has a DBP range of 3,000 to 6,000 pounds.



Available in gasoline, diesel, LPG and now electric, the Mark III offers proven success in the harshest environments. The Mark III E is one of few conventional tractors available in electric power.

[AviationPros.com/company/10363090](http://AviationPros.com/company/10363090)

### Tow Tractor NMC-Wollard Inc.

Multi-purpose, low profile Model 140 tow tractor - the tractor of choice for Corporate Aviation and Regional Jet Operators. The Model 140 pushes, pulls, plows snow, handles baggage, moves cargo, and offers more versatility than dedicated pushback machines. Get the most utility for your capital investment.



[AviationPros.com/company/10025099](http://AviationPros.com/company/10025099)

### Unibody Frame Construction Taylor-Dunn Manufacturing



Available with multiple engine packages to meet various environmental conditions. The unit is equipped with steel unibody frame construction for durability and reliability. The unit has excellent steering capability and maneuverability.

[AviationPros.com/company/10027737](http://AviationPros.com/company/10027737)

## INTRODUCING A WHOLE NEW PHILOSOPHY OF SOLID STATE FREQUENCY CONVERTER DESIGN



Aircraft are getting bigger, but as exciting as these new giants are, we all know that "bigger" also means "more power." That's why our R&D team has created the Hobart PoWerMaster® 2400. With its future-proof 400% overload capacity, Plug & Play voltage calibration and exceptionally clean power, the 2400 represents a whole new philosophy of customer-centric ground power equipment design. And we can't wait for you to see it.

Discover the Hobart PoWerMaster® 2400 at [www.ITWGSE.com](http://www.ITWGSE.com).

Headquarters: 11001 US Hwy.  
41 North Palmetto, FL 34221 U.S.A.  
Phone: 941.721.1000 • Fax: 941.721.1087  
sales@itwgse.us • www.itwgse.com



**PLUG & PLAY**  
UNIQUE VOLTAGE QUALITY

HOBART is part of ITW GSE—the world's leading supplier of ground support equipment.

**ITW GSE HOBART**

It's all about connections

[AviationPros.com/company/10017414](http://AviationPros.com/company/10017414)

[www.juniper-liverpool.com](http://www.juniper-liverpool.com)



Part no: JMP/CFM56/D/4777/C200. NSN: 1730-99-668-7936

**The Juniper 2x25 gallon wash rig with accessory tooling for all engine types.**

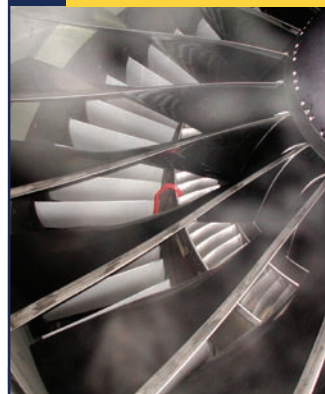

**Times are tough. You need flexible, cost effective engine washing. You need Juniper.**



Tel: +44(0)151 733 1553  
Email: [gse@juniper-liverpool.com](mailto:gse@juniper-liverpool.com)

[AviationPros.com/company/10017987](http://AviationPros.com/company/10017987)

# SAFETY & COMMUNICATIONS

## Safety Clothing

### Transportation Safety Apparel



Transportation Safety Apparel provides workers with a variety of reflective safety products, safety apparel, and protective accessories, including

ANSI-compliant, and high-visibility, fluorescent clothing.

[AviationPros.com/company/10810973](http://AviationPros.com/company/10810973)

## Wireless Headsets The Eartec Company

The Eartec Company offers ComSTAR, a new generation of full duplex wireless headsets for aircraft maintenance crews that need instantaneous, hands-free voice communications. The



system enhances jobsite productivity and safety affording up to 16 users the ability to talk just like on a regular telephone within an 800-yard range. They feature miniaturized wireless circuitry and antennas built right inside the ear cup. It is totally portable and powered by rechargeable battery or AC power. The system is dual channel and includes a conference switch

so that two separate groups can either talk privately or combine their signals. No FCC licensing or frequency coordination is required.

[AviationPros.com/company/11295532](http://AviationPros.com/company/11295532)

Not just a... tug

It's a... **LEKTRO** Since 1945

[www.lektro.com](http://www.lektro.com) • [sales@lektro.com](mailto:sales@lektro.com)



**LEKTRO**

The ultimate aircraft tug...

**800-535-8767**  
**503-861-2288**

1190 S.E. Flightline Drive  
Warrenton, Oregon 97146 USA

[AviationPros.com/company/10017532](http://AviationPros.com/company/10017532)

**New 28,5 VDC  
Power Generator**

Produced by: AeroPower MANUFACTURING  
[www.APmanufacturingINC.com](http://www.APmanufacturingINC.com)



Removable Panels

easy access

quiet system

friendly

Safe PLUG



easier to use  
simple to maintain

Ask for our  
Leasing  
program



Distributed by:  
Servicore G.S. Corp, Miami, FL. U.S.A.  
Ph: 305-888-0189 | [www.GSExp.com](http://www.GSExp.com)

[AviationPros.com/company/10017767](http://AviationPros.com/company/10017767)

## SAFETY & COMMUNICATIONS



### Protective Bumpers Carson Mfg.

Protect aircraft from accidental damage by relying on Carson Mfg. Safety Bumpers for all GSE. Carson Safety Bumpers are specifically designed to attach to airline baggage carts, service equipment and service docks to protect aircraft and equipment from accidental scratching or denting which can lead to breaches in the aircraft fuselage. Personnel are also protected from injury from overhead obstructions and sharp edges.

[AviationPros.com/company/10810920](http://AviationPros.com/company/10810920)



### Cloud-based GSE Monitoring Access Control Group

AssetPro is a cloud hosted solution to monitor GSE fleets across your airport network. It monitors ramp agents, usage, abuse, location, fuel and provides alerts if exceptions occur. It runs on a Windows Embedded platform.

[AviationPros.com/company/12012924](http://AviationPros.com/company/12012924)



### AvRamp I.D. Systems Inc.

Managing a fleet of aircraft ground support, operations and handling vehicles in an airport creates many significant, proven benefits. I.D. Systems' patented vehicle management system, AvRamp™, helps you increase productivity, establish total visibility and accountability of vehicles and operators through vehicle access control, improved safety and security, and reduced maintenance and operating costs.

[AviationPros.com/company/10184914](http://AviationPros.com/company/10184914)



### Wireless Ground Support Flightcom Corporation

Flightcom supports hundreds of thousands of commercial and military flight crews and ground support personnel with communication systems that deliver clear communication, even under the most challenging circumstances.

Its wireless ground support systems keep aviation and ground crews safe, effective and productive during aircraft ground pushback, marshaling, maintenance, and deicing operations.

[AviationPros.com/company/10441101](http://AviationPros.com/company/10441101)



### WingWalker Railhead Corporation

The WingWalker is a wireless collision avoidance safety system that prevents accidents during pushback operations by providing advanced warning to tug operators. It will improve your safety performance benchmarks while avoiding costly downtime and repairs from avoidable collisions.

[AviationPros.com/company/10615130](http://AviationPros.com/company/10615130)

# SUPPORT from the ground up

## Carts

Baggage

Lavatory

Fuel Service

Oxygen/Nitrogen

Potable Water

& Container Dollies



**Par-Kan**  
COMPANY  
Ground Support Systems

**Call today for  
our complete  
support line**

**800-291-5487** [www.par-kan.com](http://www.par-kan.com)  
Silver Lake, Indiana  
[gseales@par-kan.com](mailto:gseales@par-kan.com)

[AviationPros.com/company/10017637](http://AviationPros.com/company/10017637)

## NEW Over Molded Cable EcoNose-M®

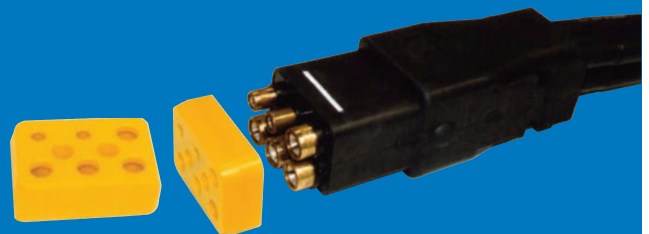

### LONGER LASTING CABLE ASSEMBLIES

By replacing the severe wear area in a ground power plug with a super tough high density (HD) polymer, the life of the cable assembly is significantly increased.

- Reduces wear on the plug nose and protects plug contacts
- HD polynose can be changed in 60 seconds on the ramp for quick return to service
- Tapered nose is compatible with all aircraft
- Available for Over Molded and Attachable® cable assemblies

Order: Replaceable Nose Plate with Screws: 2-8309P7B



**ANDERSON AIRMOTIVE PRODUCTS Co., Inc.**

994 Jefferson Street, Fall River, MA 02721

Tel (508)646-0950 / Fax (508)646-0966

[sales@andersonairmotive.com](mailto:sales@andersonairmotive.com) • [www.andersonairmotive.com](http://www.andersonairmotive.com)

®EcoNose is a registered trademark of AAP

[AviationPros.com/company/10016997](http://AviationPros.com/company/10016997)

## SAFETY & COMMUNICATIONS



### 9900 Wireless Communication System David Clark Company Inc.

David Clark Company's quality-built headset communication equipment provides clear communications and hearing protection during pushback, deicing and maintenance operations. Our 9900 Wireless Communication System provides maximum mobility and improved safety during ground support operations.

[AviationPros.com/company/10441040](http://AviationPros.com/company/10441040)



### Aircraft Guidance System ITW GSE J&B AVIATION

JB 1900 Docking System uses both human and mechanical components to guide aircraft for docking positioning. The automatic aspects are comprised of aircraft alignment and a fail safe feature to stop the aircraft in case of emergency. The human aspects of the device allow the handling agent to control the parking of the aircraft while observing critical ramp operations.

[AviationPros.com/company/10024985](http://AviationPros.com/company/10024985)



### Trisoft Aircraft Covers Trisoft Covers Inc.

Trisoft is the Global Leader in foam protection covers for the aviation industry. Our patented crosslink foam covers protect the aircraft from damage and reduce employee injuries during maintenance and manufacturing.

[AviationPros.com/company/10338471](http://AviationPros.com/company/10338471)

### Safedock A-VDGS

#### Safegate Airport Systems Inc.

The Safedock A-VDGS is fully-automated and uses three-dimensional laser scanning to identify an approaching aircraft and provide active azimuth alignment and stop guidance via a high-visibility, multi-color LED display. Safedock provides guidance to pilots in both seats and can accommodate multiple centerlines with one system.

[AviationPros.com/company/10024829](http://AviationPros.com/company/10024829)



### Pushback Headset Comprehensive Technical Solutions

CTS' M2 is a high quality, classically styled pushback headset with a budget friendly price. CTS can supply quality push-back communications equipment including headsets, heavy-duty extension and splitter cables.



[AviationPros.com/company/11191856](http://AviationPros.com/company/11191856)



### Safety Markers Plasticade

Plasticade manufactures a variety of safety cones, markers, and channelizers with or without retroreflective sheeting that are perfect for ground support applications.

[AviationPros.com/company/12012967](http://AviationPros.com/company/12012967)

## Mercury GSE Ground Support Equipment

[www.mercurygse.com](http://www.mercurygse.com)

for current stock of air starts, bag tugs, beltloaders, bobtails, crew and passenger stairs, gpu's, loaders — main and lower deck, tow tractors and other items.

**SALES LEASE RENTAL APPRAISAL**

### WE BUY SURPLUS GSE

PH: (562) 653-0654 FAX: (562) 653-0665  
E-MAIL: [dtaylor@mercurygse.com](mailto:dtaylor@mercurygse.com)  
12519 Cerise Ave., Hawthorne, CA 90250

[AviationPros.com/company/10017592](http://AviationPros.com/company/10017592)

## GSE International ERJ + CRJ GSE SPECIALISTS

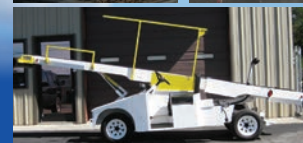

**WE BUY,  
SELL, &  
REFURBISH**  
★ **US MADE** ★  
**GROUND  
EQUIPMENT**

**954-632-2851**  
[www.gseintl.com](http://www.gseintl.com)

[AviationPros.com/company/10018176](http://AviationPros.com/company/10018176)

## DAVIN Inc.

**SALES, LEASING,  
FINANCING**

631/499-6363  
Fax: 631/499-4222

[www.DavinGSE.com](http://www.DavinGSE.com)

### AIR CONDITIONERS

1991 TLD Ace 802-620, F600 mounted 110-ton unit.  
2006 TLD Ace 302-H-CUP 24-Ton Cooling, with Heat Option.  
(2) 2007 TLD Ace 802-H-CUP 115-Ton Cooling with Heat Option

### AIR START UNIT

2007 Tronair, SA280G2 Stored Air Start. 260lb mass usable air  
1992 S&S Model TMAC-250 PPM, powered by Detroit diesel.

### BAGGAGE/CARGO TOW

### TRACTORS

2010 TUG, MA-40-27LP Ford LPG w/cab.

2001 TUG, MA-30-1 Ford 300 gas, w/cab (2 avail)  
2003 TUG, MT-8-1 Ford gas 8K DBP, w/cab (2 avail)  
2008 Harlan HTAB-40, Cummins diesel, w/cab (2 avail)  
2003 Harlan HTAG-80 Ford gas 8K DBP, w/cab (2 avail)  
1997 Toyota, Model 2-02TD25 diesel engine.

### BELTLOADERS

2007 NMC-Wollard, Model TC-888 4-cyl. Deutz diesel engine.  
2002 TUG, Model 440E, 48 volt electric with built-in charger.

### CONTAINER LOADER

1988 LANTIS, Model 818-218-161-125, High & Wide 161" elevator.  
2006 FMC/JBT Commander 15i with wide option.

### GROUND POWER UNITS

2005 Hobart, Model 120CU24P5, 120 KVA  
2008 TLD, Model GPU4090-T-CUP, 90 KVA  
2001 Hobart, Model Jet-Ex5D 28.5 VDC

### HEATERS

1997 Air-A-Plane Model 5050D, Deutz diesel engine.  
1994 Air-A-Plane, Model 5050GF, Ford 300 gas engine

### PASSENGER STAIRS

2012 NMC-Wollard, Model CMPS170, 77.5" to 170.5" like new.  
2001 Stinar, Model SPS-3518 GMC diesel 96" to 228"  
1998 Stinar, Model SPS-7026 Ford F-Series diesel 184" to 314"

### PUSHBACK TRACTORS

1998 NMC-Wollard, Model 140, Perkins diesel, 10K DBP.  
2005 FMC, Model B400 Deutz diesel, 4WS, w/cab, 35K GVW  
2000 S&S TUG, Model GT-50DZH, Deutz diesel, 60K GVW  
2010 JBT, Model B1200 Cummins Diesel, w/cab 100K GVW



**FORTBRAND**  
SERVICES INC

[www.fortbrand.com](http://www.fortbrand.com)

516 576-3200

fax 516 576-3221

[info@fortbrand.com](mailto:info@fortbrand.com)

**SALES RENTALS LEASING FINANCE CONSULTING**

### AIRCRAFT TOW TRACTORS

JBT B-250 (30,000 lbs GVW)  
TLD TPX-200MT towbarless  
Eagle TT-12 (12,000 lbs DBP)  
NMC-Wollard 6,000 lbs DBP cargo tractor  
Eagle TT-8 (8,000 lbs DBP)

### BAGGAGE TRACTORS

Tug MA50, gas + diesel  
Harlan HTC 50, gas

### MAINTENANCE STANDS

B-4 stand - 37"-87"  
B-5 stand - 88"-135"

### AIR STARTS

TLD 150 PPM  
S&S 250 PPM  
**GPU**  
TLD 90Kva + 120Kva  
Hobart Jet Ex 5D 28V

### CONVEYORS

NMC-Wollard TC-888, diesel  
Tug 660, gas

### LAVATORY TRUCK

Wollard TLS-770

### PASSENGER STAIRS

Phoenix Metal PAS200 wide body  
Stinar SPS-2513 narrow body  
Clyde 15F2820 narrow body, towable  
Wollard TLPH-252, widebody

### AIR CONDITIONERS

TLD 302 30-ton w/heat  
Trilectron DAC200 20-ton w/heat

### HEATERS

Trilectron 5050D

**FOR SALE OR LEASE**

Advertise in Ground Support Magazine  
and watch your income

# EXPAND

FOR MORE INFORMATION CONTACT  
MICHELLE SCHERER AT

1-800-547-7377 X 1314 • [MScherer@AviationPros.com](mailto:MScherer@AviationPros.com)

Calibration  
Specialty  
Inc.

Calibration Service and  
Sales Traceable to NIST

[www.calibrationspecialty.com](http://www.calibrationspecialty.com)

P: (972) 438-3774

F: (972) 438-3874

Irving, Texas

Use us for your GSE needs



- Electronic Repair
- Equipment and Training
- Replacement Parts

(305) 888 01 89  
(305) 851 81 44

Cualquier asesoría  
también en español

GPU • ASU • ACU • LOADERS • ENGINES  
BAGGAGE TRACTORS • BELT LOADERS  
TRANSMISSIONS • RAMP ACCESSORIES  
[www.SGSequipment.com](http://www.SGSequipment.com)



## Ground Support Specialist

CALL ADAM AT  
662-342-1412

or email:

[ADAM@GSSONLINE.COM](mailto:ADAM@GSSONLINE.COM)

### Aircraft Deicers

FMC Trump 2100	7 Units	1994
Trump D2-40	1 Unit	1988
FMCTX 2000II	2 Units	1995

### Other GSE

NMC Wollard 140 Pushback Tractor	1 Unit	2008
TUG MC-15	1 Unit	1987
Hobart Dual 60 KVA AC/DC	1 Unit	2001
Hobart 60 KVA	1 Unit	2005
JBT-Aerotech Jet Aire- Mobile PCU	1 Unit	2011
WASP Beltloader	3 Units	2007
FMC Commander 15i	1 Unit	2003

**All Listed Items:  
For SALE, RENT,  
or LEASE!**



Steve Smith

## Is Next Year *The Year*?

*2015 may bring good news for the GSE industry.*

By Steve Smith

**A**s a modest Cubs fan and robust Bears fan, I can't help but fall into the comfortable trap of thinking next year is *the year* for a big win for either team or both.

The Cubs continue to sustain hope for reasons that escape me. As for the Bears, I'm writing this a couple of days after their humiliating loss to the Packers on Sunday night so I'm sure I'll be waiting a year (or more) for some good football news.

And so it goes with GSE. Will 2015 bring good news or will it be a rebuilding year of sorts?

A couple of items promise optimism for the industry:

### SILVER LINING

**Old Equipment:** Earlier this year at our own trade show, we heard from several manufacturers who told us that so much of the GSE stock currently in use is ancient – even by GSE standards of longevity. Many expected airlines and other related equipment buyers to finally reach for their checkbooks. We've since been to a couple of trades shows in the past month and continue to hear these same sentiments.

**Sales Are Up:** Take a look at two recent financial reports, one from a very large GSE manufacturer and another from one not quite as large.

JBT Corp. said revenue for the third quarter was up 4 percent to \$243.2 million. While the company doesn't break out sales from its ground support division, JBT did add that operating profit increased by 16 percent led by expansion at both its food service business and JBT AeroTech.

Meanwhile, Air T reported a 43 percent increase in revenue to \$34.6 million for its fiscal second quarter. A bright spot in that growth comes from Global Ground Support where GSE sales were up 127 percent to \$10 million.

**Airline Stocks Could Lift Off:** Most stocks of U.S. carriers took a beating recently on account of general market weaknesses and specific concerns over Ebola. But Wall Street thinks that falling oil prices and cheap valuations should revive shares. And before the Ebola outbreak made the news, airlines all reported very positive news about financial performance.

### DARK CLOUD

Then again, you don't need me to tell you how tough it is to make a buck within the aviation industry. While much of the news mentioned above sounds promising, most of us just don't know what to expect anymore.

In preparing to write this editorial, we read the one that appeared here in last November's issue. We related plenty of good news we heard after attending the 2013 inter airport Europe show, not the least of which was a sizable increase of 20 percent given over to expanding the outside exhibit space that's typically allotted for ramp equipment.

Anyone who rides inside the plane knows airlines have created and raised fees on everything from checked luggage to ticket changes to just snagging an aisle seat without necessarily adding anything to the customer service experience.

And what about everyone on the ground and at the gate? What are your thoughts on the coming year? Drop us an email at [smith@aviationpros.com](mailto:smith@aviationpros.com) and let us know.

### EDITORIAL ADVISORY BOARD

**AeroVironment/PosiCharge** – Ryan Gibson  
**AGERanger.com** – Darryl Clark  
**Aviance** – Alain Chappler  
**Charlotte of America** – Rob Lamb  
**Delta Air Lines** – Joe Fuqua

**Elite Line Services, Inc.** – Dewey Kulzer  
**Fortbrand Services** – Fred DiBenedetto  
**J&B Aviation Services** – David Janis  
**JBT AeroTech** – Jim Cherrett, Virginia Salas  
**Sage Parts** – Michael Bloomfield

**Triton Technologies LLC** – Debra Guinand  
**United Airlines** – Jody Cope

# WARNING!

## DID YOU KNOW!?

Some smaller sized 400Hz aircraft demand higher overload ratings as compared to larger aircraft.



Offers more **overload!**

45kVA provides 300%!

30kVA provides 450%!

20kVA provides 675%!



Unitron LP | 10925 Miller Road | Dallas, TX 75238  
Tel: 214 343 7511 | Fax: 214 341 2099 | [www.unitronlp.com](http://www.unitronlp.com)

# Go Green

## With Ford Advanced Technology Engines.

*A Green Alternative to Diesel from*

**ENGINE  
DISTRIBUTORS  
INC.**



### YOUR Tier IV Solution

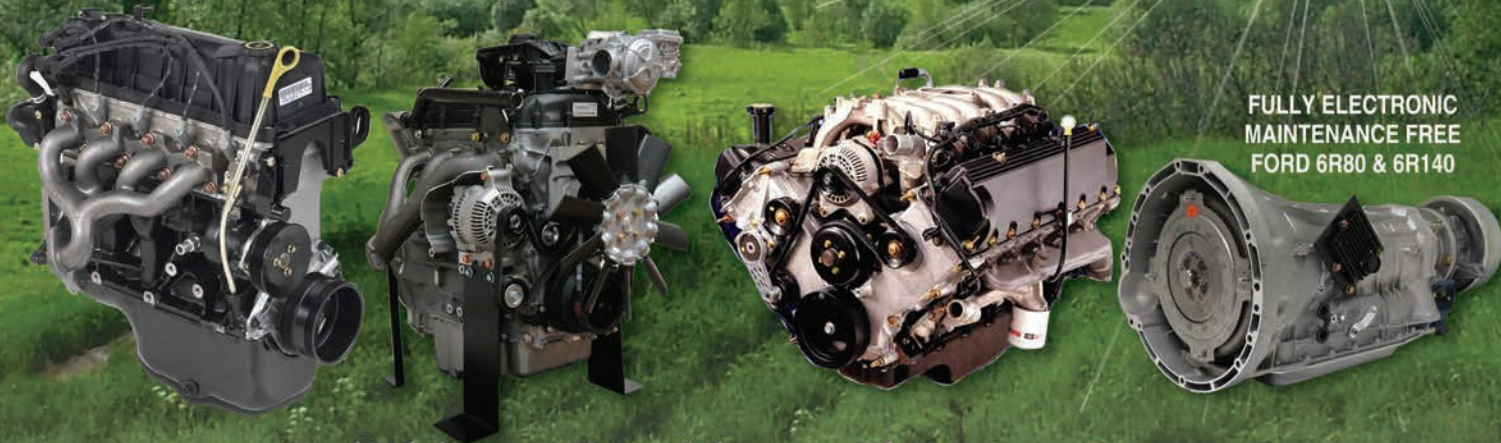

FULLY ELECTRONIC  
MAINTENANCE FREE  
FORD 6R80 & 6R140

**Reliable — Durable — Clean — Green.**

Featuring a complete line of EPA and CARB Certified 1.6, 2.5, and 6.8 L LSI Engines ranging from 20 to 200 hp. Available in Gasoline, LPG, CNG, Natural Gas and Dual Fuel. Our engines are the solution to high priced Tier 4 Diesels. Secured Volumes, Longer Life Cycles, Dry Fuel and Flex Fuel Valve Trains – You Can Find It At EDI. Performance you can count on!

**Contact One Of Our Distributors Today!**

Our line of LSI industrialized Ford engines are serviced through a Global Dealer Network.

**Anderson Industrial Engines Co.**  
Omaha, NE 402-558-8700

**Southwest Products Corp.**  
Phoenix, AZ 877-779-3581

**Diesel Power Equipment**  
Chicago, IL 877-876-3732  
Farmington, MO 800-876-3732

**Engine Distributors Inc.**  
Archdale, NC 800-220-7080  
Blackwood, NJ 800-220-2700  
Ft Lauderdale, FL 800-257-6605  
Holliston, MA 800-220-2700  
Jacksonville, FL 800-342-3575

**Engines, Inc.**  
Jonesboro, AR 800-562-8049

**Powertech Engines Inc.**  
Fresno, CA (800) 750-1776  
Fullerton, CA (800) 784-1776

**Perkins Pacific**  
Ridgefield, WA 877-877-3311

**McDonald Equipment Co.**  
Willoughby, OH 800-589-9025  
Portland, MI 800-445-5273

**M. G. Bryan  
Equipment Co.**  
Grand Prairie, TX  
972-623-4300

**D A C Industrial  
Engines Inc.**  
Dartmouth, NS, Canada  
902-468-3765

**Marindustriel**  
Montréal, QC, Canada  
514-342-2748

Oakville, ON, Canada  
800-866-3831

**Simson Maxwell**  
Edmonton, AB, Canada  
800-374-6766

Calgary, AB, Canada  
800-374-6766  
Port Coquitlam, BC, Canada  
800-374-6766

Nanaimo, BC, Canada  
800-374-6766  
Prince George, BC, Canada  
800-374-6766

**All Marine Spares**  
Mona Vale, N.S.W., Australia  
61-2-99972788

**Compagnia Tecnica Motori S.p.A.**  
Milano, Italy  
+39 0245058238

**Fornaut Ehm Sa**  
Le Pre St Gervais, France  
01133148450394

**Power Torque Engineering Ltd**  
Binley, Coventry, UK  
011-44-247-663-5757

**Sauer Motive Systems**  
Sauer and Sohn KG  
Dieburg, Germany  
011-49-607-120-6330

**Engine Distributors Inc. • 400 University Court • Blackwood, NJ 08012**  
Phone: (856) 228-7298 or (800) 220-2700 • [www.edi-dist.com](http://www.edi-dist.com)