

controldesign.com

control design

F O R M A C H I N E B U I L D E R S

NOVEMBER 2014

STATE OF TECHNOLOGY REPORT

I/O Systems

One Convenient eBook with the Latest
Technology Trends, Back-to-Basics Tutorials
and Application Stories on Input/Output
Systems—from Power Supplies to Terminal
Blocks to Industrial Connectors.

TAKING IT TO THE eXTREME

THE WAGO-I/O-SYSTEM FOR eXTREME APPLICATIONS



eXTREME VIBRATION up to 5g acceleration
eXTREME TEMPERATURE from - 40°C to +70°C
eXTREME ISOLATION up to 5 kV impulse voltage

WWW.WAGO.US/XTR

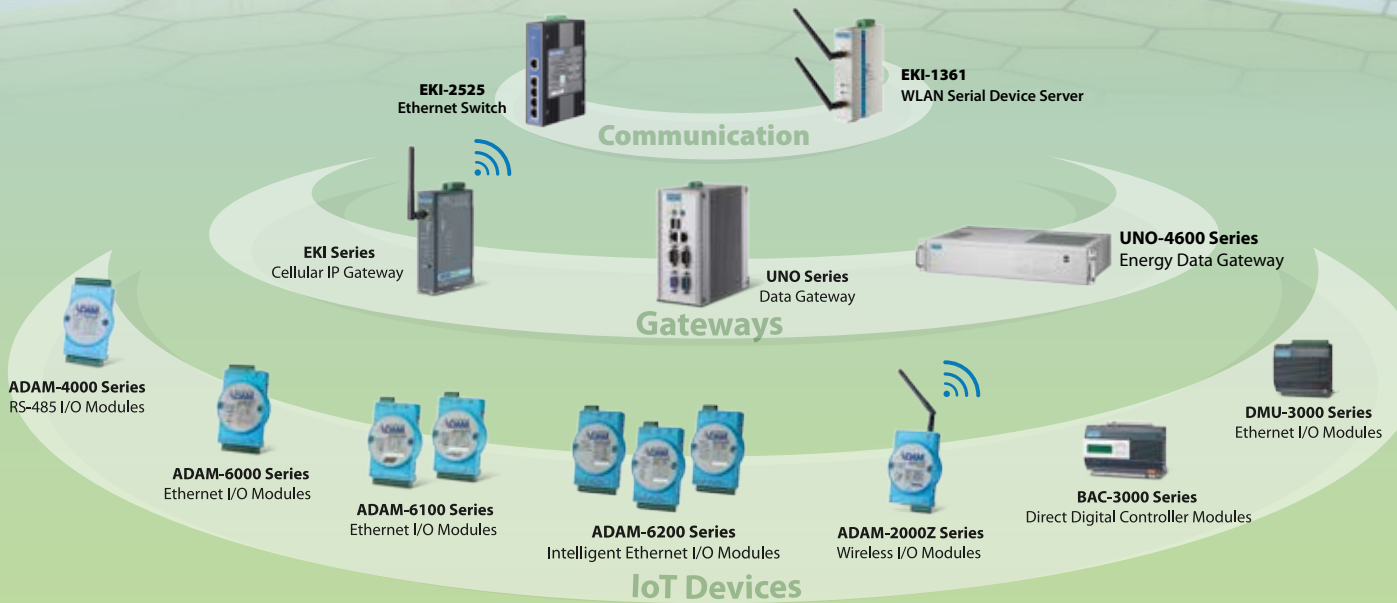



Table of Contents

I/O Technology Reflects Automation Industry Trends	7
Trends in Technology	
Ripped, Not Ripped Out	9
Machine-Mount I/O Go Everywhere	16
Arc Flash: Not My Fault	19
Fast Movers	23
Mix and Match I/O? Maybe	29
Terminal Blocks Combine Functions	30
Getting to a Better-and Cleaner-Source	31
Network Devices Need Software Support	33
Sensing Without Wires	36
Back to the Basics	
Think Global, Connect (Sometimes) Local	39
Make Circuit Protection Easier	40
Analog I/O Serves Real-World Control	42
The Right Cable Connection	46
High-End Protection for Low Power	48
Device Protection in the Danger Zone	50
Technology in Action	
Flexibility Is Key to Automated Welding	54
Waterjet Cutting Systems for the Toughest Tasks	58
Flexible Conveyors? Look Up	62
Control the Roll	63
Surface Finisher Makes a Modular Move	65

Improve Efficiency, Safety, and Profitability with Advantech IoT Solutions



Instrumented



Interconnected



Intelligent

ADVANTECH

Enabling an Intelligent Planet

Highly Reliable IoT Devices & Gateways

Advantech's IoT solutions help improve and automate data collection, concentration and curation enabling end users to take full advantage of visualization and analysis software like WebAccess. Advantech WebAccess is a smarter browser-based HMI/SCADA software to help you easily develop your IoT projects.



Advertiser Index

Wago www.wago.us/xtr	2
Advantech www.advantech.com	4
Opto 22 http://op22.co/ethernetio	6
Omron Automation and Safety www.omron247.com	8
Murrelektronik www.murrinc.com	15
Weidmuller www.weidmuller.com/u-remote	18
IDEC www.IDEC.com/PS6R	22
Lumberg Automation, A Belden Brand www.lumberg-automationusa.com	28

Distribute Intelligence.

- Reduce system load
- Maintain key processes
- Save programming time and expense

Intelligent remote SNAP Ethernet I/O from Opto 22.

Put it to work for your system.



Visit <http://op22.co/ethernetio> or scan this QR code with your smartphone.

40
YEARS
1974-2014

OPTO 22
Automation made simple.



Made and supported in the U.S.A.

Call us toll-free at 800-321-6786



I/O Technology Reflects Automation Industry Trends

Ethernet Adoption, Distributed Functionality in Lockstep with Modular Machine Movement.

The essential function of input/output (I/O) in an industrial automation system is to broker conversations between the physical world of machines and the digital world of today's microprocessor-based controllers. Real-world measurements must be communicated and converted into 1s and 0s a controller can understand; the controller's decisions, in turn, must be communicated and translated into the real-world movements of motors, valves, and actuators. Measurements come in, instructions go out. Beyond that, I/O functionality today is packaged, distributed and delivered in an increasingly bewildering variety of ways.

At one extreme are centralized, cabinet-enclosed I/O modules, mounted together with a power supply on DIN rails and connected via terminal blocks and point-to-point wire pairs to each and every individual sensor and actuator on a given machine. For terminating the wires themselves, machine builders have the option of screw, spring or cage clamp technologies, or may use more expensive but often expedient industrial connectors. At the other I/O architecture extreme are battery-powered sensors that broadcast their readings wirelessly through a mesh network to a network access point and on to the controller. "Where's the I/O now?" one might ask. In between are varying degrees of remote I/O architectures that distribute blocks of I/O in local junction boxes networked back to a central controller, or as industrially hardened blocks mounted directly on the machine frame.

In short, the engineering of machine I/O today is a complex decision-making process that includes far more than simply counting sensors and actuators and making sure you have enough I/O of each type plus a handful of spares in the controller cabinet.

The move toward increasingly distributed I/O, for example, has been driven in part by end-user demands for more modular, more flexible machines that can accommodate rapidly shifting demand for different products and product variations.

To address this need, OEMs increasingly build machines in modular sections that can operate as functional clusters or as coordinated subsystems. With distributed I/O, the user need simply add power, a network connection, and any other necessary utilities to a machine subsection and it's off to the races. Distributed I/O also makes it easier for OEMs to install and commission its machines; shippable machine modules can be fully pre-tested at the factory, rather than after extensive (and often error-prone) onsite wiring required by more centralized I/O approaches.

Hand in hand with the trend toward distributed I/O architectures is the increasing adoption of Ethernet connectivity down to the I/O module level. While there remains a place—for now—for industry-specific protocols at the sensor level, Ethernet variations such as EtherNet/IP, PROFINET, EtherCAT and CC-Link, have all but taken over the task of communication among I/O modules and the controllers and control systems with which they work.

Tech Trends, Back to Basics and Case Studies

This balance of this *State of Technology Report* explores in greater detail these and other technology trends in the arena of I/O. Drawn from the most recent articles published in the pages of Control Design, this special report includes articles on emerging trends, basic primers and case histories illustrating the latest technology in action. We hope that you find it useful.

- The Editors



Trends in Technology

Ripped, Not Ripped Out

An Old Automation System Always Can Be Removed and Replaced With a New Version. There Are Times When Deciding to Retrofit It or Just Keep It Running Can Be Better Options

by Dan Hebert, PE, senior technical editor

If you work for a machine or robot builder OEM, or if you're a manufacturer with machines and/or robots in your facility, then the subject of automation system obsolescence will arise sooner or later. When it does, you have three options.

One is to rip and replace the entire existing automation system with a new one, an option covered in detail in our June 2013 CONTROL DESIGN cover story "Old Machine, New Life" (www.controldesign.com/articles/2013/montague-old-machine-new-life/) and touched on in this article. This is the highest-cost option with the most downtime, but the result is a new system that can run for many years.

The second option is to keep the old automation system up and running for as long as possible through a combination of wit, grit and spit. This is the lowest-cost option, but can't be sustained forever, as sooner or later it will become necessary to either rip and replace or retrofit.

The third option is to retrofit part of the automation system with new components, while keeping other parts in place.

Retrofit Advantages

In almost all cases, a retrofit will require less downtime than a rip and replace because the scope of work is greatly reduced. It's also better than a simple "keep running" solution because it replaces the parts of the automation system that cause the most problems.

In many cases, the base machine is fine, but the control system needs upgrading. Georg Transformer (www.georg.com) in Germany had that problem with a 1981 lamination shear that it builds for transformer manufacturers. The machine had an ancient 486 PC for the controller. Georg found an upgrade path that let the original I/O work with a new controller in an almost plug-and-play project. (See the sidebar, "Save the Old I/O," p. 26 for more on this retrofit.)

Another reason to retrofit arises when support has disappeared for the original control system. Michael Lindley, vice president at Concept Systems (www.conceptsystem-sinc.com), a system integrator in Albany, Oregon, first got involved with an aerospace company 12 years ago, when the company that installed and supported a rivet inspection control system went out of business. "We first duplicated the controls, supported them through the life of the system, then re-programmed the machine with all new hardware, but with the identical look and feel," Lindley explains.

The inspection system checks each rivet just before it's inserted into the wing skin and crushed to make sure it's the right rivet, is not upside down and is oriented precisely vertically. It communicates directly with the CNC system, and uses a pair of orthogonal cameras (cameras oriented so that one sees a



NEW PLC, BETTER BREW

Figure 1: Brains Brewery in the U.K. replaced two 27-year-old PLCs with a new PLC, retaining the original I/O and field wiring and linking the controller and the I/O with a gateway



Trends in Technology

front view and the other a side view) with custom backlights.

“We installed the first system with Visual Basic 6 and Windows XP,” Lindley says. “The new system uses Visual Studio 2012 and Windows 7/64. We increased the resolution with the third-generation system, although the accuracy of the previous system was adequate.”

Upgrading because of Windows operating system problems is a major reason for retrofits. Support for Windows XP ended in April 2014, affecting thousands of PC installations.

One force driving the switch to Windows 7 is the old age of the PCs that run Windows 2000, Windows XP and older operating systems. We often hear that when the old PC dies

SAVE THE OLD I/O

The Automate Co. (www.automateco.com) in Pacific, Missouri, is a system integrator that’s been building machine control systems since 1997. Barrett Davis, principal at Automate, says “I am aware of no one that’s still manufactures, sells and supports I/O hardware that was being built in the early ‘80s. We have multiple customers for which I provided upgrades to existing machine control systems without having to replace the original I/O or field wiring.” he says. His company is currently upgrading a lamination shear at Georg Transformer that cuts laminations to size and shape.

The transformer division of Georg (www.georg.com) makes fabricating equipment used by transformer manufacturers all over the world. “We’re updating from a 486 industrial PC controller driven by C++ and assembly language programming to an Opto 22 PAC controller. We’re simply switching out all six existing parallel I/O rack cards with 32 channels of digital I/O brain cards and connecting Ethernet directly to the original rack.”

In addition to the new migration hardware, Opto 22 provided the command set and serial ports that let the new controller talk directly to the old equipment.

“One could say that the retrofit migration hardware cost is pretty close to brand new I/O hardware from Opto 22,” Davis notes. “However, no shutdown is needed. Plug-and-play switchover to the new cards makes it possible to design the new program on weekends while the machine is down, eliminating the need to shut down for an extended period of a week or more.”

Davis notes that retrofit is used in many cases because it decreases downtime. “Many manufacturers simply do not have spare production lines, so rip-and-replace could shut their operations down if a machine is taken out of production

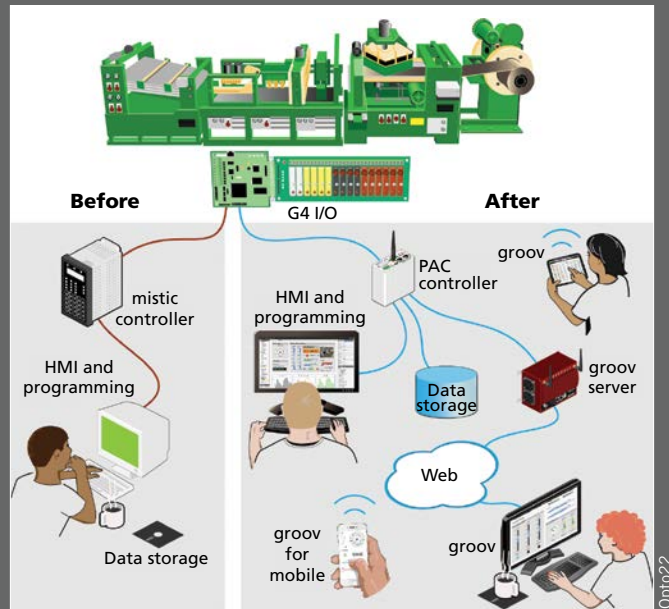

SAVE THE OLD I/O

In some automation retrofit applications, the original I/O is retained, and the controller is upgraded and will work with I/O that’s up to 35 years old.

for more than a few days,” he explains. “Although this seems an insane approach, it is in fact very common.”

Other advantages of retrofit migration include no need to rebuild the entire control panel or reverse engineer the existing wiring and take the chance of shutting the machine down for extended periods. “We leave the wiring in place and just reprogram. The new controller can be configured and programmed just as if I were installing the new PAC brains and racks,” says Davis.



Trends in Technology

TIME TO UPGRADE

AeroSpec (www.aerospecinc.com) in Chandler, Arizona, designs and builds a variety of custom automated equipment for the medical, semiconductor, automotive and defense industries. David Perkon, vice president, says he's seen many problems with legacy control systems.

"It's not uncommon to have firmware and software driver issues with legacy hardware and software," he says. "Working with a dated operating system or updating the operating system can cause issues with I/O drivers, application software and PC-based operator interfaces. A programmable controller's firmware might not be compatible with rack-mounted motion control cards and other smart modules."

Roadblocks to upgrading are many, he says. "There are the 'It costs too much money,' or 'I can't afford the downtime' customers. With many customers, not updating legacy hardware and software is more of a culture than a time-and-money issue. It's the 'It's running fine, don't mess with it' attitude. All that sounds reasonable until the reality of failures brings production to a halt. Many customers just don't want to spend the money or are afraid to upgrade until they absolutely have to."

AeroSpec is happy to retrofit new controls hardware to existing equipment. "We recently updated the automation system for a large medical-device manufacturer. The equipment ran slow and had significant quality and productivity issues. It was a machine the customer had been fixing for years."

Significant machine downtime was occurring because of product breakage, machine jams and alignment issues. A team of three maintenance technicians were required to support the 10 machines every shift. Although the technicians kept the equipment running, the root cause of the problems—the controls hardware—was never addressed.

AeroSpec performed a detailed equipment study and found the legacy control system and software were limiting



AeroSpec

IN THE RIGHT SPOT

AeroSpec designed and built this and other stations on a high-speed, thin-film-solar assembly line. This station singulates, orients and tests diodes before they're adaptively placed and welded on the thin-film product by dual-vision guided robots.

production. The machine controller and motion control hardware were upgraded.

"Replacing the motion controller with a Rockwell Automation (www.rockwellautomation.com) CompactLogix controller and Kinetix multi-axis servodrives greatly improved machine performance," Perkon reports. "The new hardware fit nicely in the existing control enclosure, and a new PanelView HMI enabled the addition of machine status, fault display, manual functions and setpoint adjustment screens."

The upgraded hardware allowed programming of a new machine sequence with a creative motion profile. "In the end, we tripled the speed of the equipment and significantly reduced scrap," Perkon beams. "The control hardware and software upgrade also helped highlight other areas where the equipment could be optimized. It's simple math. The new hardware and software quickly paid for themselves."



Trends in Technology

and must be replaced, users with control and HMI systems that are working OK are forced to make major changes. This raises another problem, Tom Edwards, Opto 22 engineer, observes: “The mandatory shift to Windows 7 and Windows 8 on all of the available newer PCs makes a change in control and HMI software a necessity, as very few of the fundamental I/O functions remain the same or are upgradeable to Windows 7 or Windows 8.”

Picking on PLCs

Brains Brewery (www.brainscraftbrewery.com) in Cardiff, Wales, was developing an increasing variety of beers, so it wanted to upgrade its yeast-handling control system to accommodate the new mixes. “The main aim of the project was to upgrade two Allen-Bradley PLC 2 controllers, which were 27 years old,” says Mike Cooper of IAC Engineering (www.iaceng.com), a system integrator in Cross Hands, U.K. “Limited downtime was available—only three days—so the six old 1771 remote I/O racks were retained, but the obsolete controllers were replaced by a CompactLogix PLC.”

The connection between the 1771 I/O racks and the CompactLogix (Figure 1) was accomplished with a remote I/O-to-Ethernet migration gateway from ProSoft Technology (www.prosoft-technology.com). “Without the gateway, a more expensive system would have been required. This solution reduced the project cost by 40%,” Cooper notes. “Commissioning time was reduced because the remote I/O cards and wiring



The Bradbury Group

ALL COILED UP

Figure 2: This Bradbury coil processing line uncoils, levels, cuts to length and automatically stacks orders. The machines are designed for a life of 20 to 30 years. The company keeps its customers’ legacy equipment running by carrying backups of all the programs that operate the equipment they manufacture.

could be retained. Only the processor and software needed to be added and commissioned, not the field wiring.” and wiring could be retained. Only the processor and software needed to be added and commissioned, not the field wiring.”

Finding a vendor that’s developed a nice piece of hardware or software designed for retrofits can solve a lot of problems. At PARI Pharma (www.pari-pharma.com), a medical device manufacturer in Germany, a control system retrofit project connected a Siemens S7 PLC to modern databases. (See the sidebar, “Upgrading Connectivity,” on p.30.)

ADVANTAGES OF RETROFIT OVER RIP AND REPLACE

1. Less downtime
2. Lower cost
3. Less required design effort
4. Reuse of existing cabinets and wiring
5. Reuse of existing I/O, HMI and/or other components
6. Fewer potential problems during commissioning and start-up
7. Reduced risk
8. Less required training
9. Fewer new spares need to be stocked
10. Better compatibility with legacy software

Keep ‘Em Running

But when times are tight and the existing machine or robot is near the end of its useful life, keeping the automation system running by hook or crook can be the way to go.

Some companies put off upgrades until they absolutely have to do them. David Perkon, vice president at AeroSpec (www.aerospecinc.com), a machine builder in Chandler, Arizona, has customers that prowl eBay and the Internet for old parts, employ maintenance people to keep the machines working, and put off upgrading as long as they can. “Keeping legacy equipment running without replacing the hardware



Trends in Technology

UPGRADING CONNECTIVITY

The eFlow nebulizer, developed by Pari Pharma (www.pari.com) in Gräfelfing, Germany, has been used to treat cystic fibrosis patients for many years. The company is currently installing software to optimize automation of its production equipment, particularly through connectivity improvements.

The company is installing Beckhoff Automation's (www.beckhoffautomation.com) TwinCAT software on an existing PC, and linking this software to an existing Siemens (www.siemens.com) S7-PLC. "Before the changeover, our technical infrastructure was somewhat inefficient," says Ronald Schmidt, project manager at Pari Pharma. "A very complex mix of control programs for the Siemens S7 PLC, as well as PC-based programs written in C++ and using National Instruments (www.ni.com) LabVIEW made maintenance without specialized programming knowledge nearly impossible. In the event of a fault, we had to call in external specialists on a regular basis."

The existing automation couldn't communicate with Oracle and SAP databases. Traceable parts management was needed for the complex production process, where two separate machining operations are executed in one manufacturing cell.

After the first production step, the part is removed, processed further and returned for another machining operation. The parts must be scanned and identified before each step. And the aerosol generator of the eFlow system passes through 12 production and testing stations.

"The data from the PLC had to be entered manually in the databases for further processing," laments Schmidt, and replacing the PLC was not an option.

"For years we looked for a machine control system that was able to communicate directly with the databases," Schmidt says. "We chose the TwinCAT Database Server in conjunction with a Profibus master terminal for the EtherCAT Terminal system from Beckhoff. However, we didn't want to and couldn't replace the old S7-PLC



SHOW US YOUR ID

Production of the aerosol generator for eFlow inhalation device takes 12 production and test facilities. Each part is scanned and unambiguously identified using an Oracle database, a new control platform and an existing PLC.

immediately during continuous operation. We were looking for an option to communicate with it via the Beckhoff system without the need for proprietary hardware."

The solution was provided by esqmate, GmbH, a system integration firm in Unterföhring, Germany. The company has an MPI software library for TwinCAT that ensures that the Beckhoff software can communicate directly with the Siemens PLC via a Beckhoff Profibus master terminal using the MPI protocol. No additional hardware, such as MPI/Ethernet gateways, was required.

The SAP system receives test data from the Oracle database, which is connected to the Beckhoff system. SAP then generates item lists, work schedules and approval reports, and manages inventory based on this data.

"Because direct communication is now possible between the existing S7-PLC, the Beckhoff platform, the Oracle database and our SAP system, we are at last able to link the control world with business management solutions," Schmidt says.



Trends in Technology

or software is a nice dream until something fails, and you've used your last spare," he says.

One of his customers kept an old machine running for years, until it started having quality and production problems. An analysis revealed that the machine was fine, but the control system needed an upgrade. (See the sidebar, "Time to Upgrade," p. 28.)

Because old PLCs are so reliable, it's often difficult to justify a retrofit. Intelligrated (www.intelligrated.com), an OEM of material handling systems in Mason, Ohio, supports its older systems, such as Alvey palletizers. "We actively support several customers who have the original PLC 2 1772 series processor," says Chris Hutson, Intelligrated's manager of product support engineering. "Although these machines were manufactured beginning in the mid-1980s, we continue to modify their PLC logic to incorporate new product patterns. Also, we provide troubleshooting for these processors, which have been discontinued by the manufacturer."

Some of their other machines over 30 years old have Modicon PLCs programmed with DOS-based PCs and manual switch panels instead of modern, touchscreen technology. "In many cases, this requires us to read 5¼-in. floppy drives to obtain old machine program files and information from original drawings."

Machine builders appear to be better at keeping legacy systems running than some vendors of control systems. The Bradbury Group (www.bradburygroup.com), a builder of metal-processing equipment (Figure 2) in Moundridge, Kansas, for example, keeps its customers' legacy equipment running by carrying backups of all the programs that operate the equipment they manufacture.

"Issues often arise when we have to support third-party equipment," says Dennis Clark, Bradbury's project software engineer. "Sometimes it's the proprietary software they provide; other times the equipment vendor might go out of business."

Bradbury builds coil processing and roll forming machines, designed for a life of 20 to 30 years. "The manufacturing life-cycle of the average electrical component is seven to 12 years," Clark notes, "but for PC-based products such as HMIs, it can be as short as three to five years."

Some vendors do their best to support older automation systems. "While no one can completely eliminate the risk

associated with legacy operating systems, some manufacturers have tools and services to maximize the life of legacy equipment and minimize risk," explains Lonnie Morris, senior manager at Rockwell Automation (www.rockwellautomation.com). "Lifecycle extension services from companies like Rockwell Automation provide service options to fit each company's individual needs."

Rip and Replace Has Its Place

Although retrofit or keep running have advantages in many scenarios, that's not always the case, as sometimes it's just better rip and replace.

"We encourage our customers to migrate from obsolete systems to current, actively supported software and hardware platforms," Intelligrated's Hutson notes. "For a soft drink company and other beverage facilities, we converted our high-speed 920 series palletizers from obsolete PLC processors to modern automation based on the ControlLogix platform. On several projects, we lowered the customer's total cost of ownership, met operational compliance regulations, and increased flexibility and performance."

Much of the time, the actual machine itself is reliable, but the control system is causing problems. For example, one of Delta Computer Systems' (www.deltamotion.com) customers that manufactures automotive components ran into a problem with servo-controlled lathes in its facility.

"The lathes were well-designed precision machines, but the servo control system was the original analog design approaching 22 years of age," explains Bill Savela, marketing manager at Delta. "While the machine still produced excellent parts, the downtime associated with the servo-control system was becoming an issue. We determined that the primary problem was the lack of reliability of the old analog control system, and they decided to replace it with a Delta servo motion controller."

And sometimes a retrofit or upgrade isn't enough. "Whether it's old software talking to new devices or new software talking to old devices, a pop-up message warning of a compatibility issue is common," notes AeroSpec's Perkon. When these and other types of compatibility issues arise between old and new systems, sometimes the entire control system has to be replaced. ■

Does your I/O connectivity solution *really* satisfy your budget?



At Murrelektronik, your wiring solution is very important to us. We don't sell PLCs or Sensors so our main concern is how to connect them together in the best possible way. We focus on the machine layout and take a personal approach to evaluating your wiring effectiveness.

Email us at lunch@murrinc.com to schedule a lunch and learn for your group to see how we can save you over 40% of your I/O connectivity assembly time – and we just might save on some hardware costs while we are at it!



stay connected

1400 Northbrook Pkwy, Ste 300 | Suwanee, GA 30024 | P: 770-497-9292 | murrinc.com



Trends in Technology

Machine-Mount I/O Go Everywhere

by Jim Montague, Executive editor

Once you're willing and able to get out of your cabinet or other comfy shelter, you can travel anywhere to provide assistance—if you bring the right tools and protection. This is just as true for machine-mounted I/O devices.

“Builders want to get the costs out of their machines and produce them faster with the same people, and so they're learning they can assemble controls faster with machine-mount I/O,” says Will Healy, marketing manager for networking products at Balluff (www.balluff.com). Consequently, technical advances and regulatory reforms allow many popular I/O components governed by IP20 to take on their own IP67 protection, so they can do many of the same jobs outside their former enclosures.

“Customers are demanding higher IP ratings and simpler installation,” says Helge Hornis, manager of the Intelligent Systems Group at Pepperl+Fuchs (www.pepperl-fuchs.us). “Where IP65 used to be good and IP67 was great, many customers won't settle for IP65 any longer, and really want IP68/69K.”

To achieve this machine-mount I/O simplicity, single- and two-piece designs are best, Hornis explains. “Fifteen years ago we designed I/O housings with bases that contained moving parts,” he notes. “Now this same functionality is available in designs that are simpler, more rugged, and offer higher IP protection at lower cost. Installation time probably is reduced by a factor of five to 10.”

Pepperl+Fuchs offers Connect & Done I/O modules, which are so small that most users don't even need to mount them in the usual way, Hornis adds. “Once connected to the network cable, they're simply dropped into the cable tray.”

Free of its cabinet-based straightjacket, machine-mount

I/O devices have diversified, too. Adoption of I/O modules with sealed connectors has picked up speed for five or six years, and suppliers also provide more interface types and capabilities, such as functional safety, motion control and position feedback, reports Kurt Wadowick, I/O specialist at Beckhoff Automation (www.beckhoffautomation.com).

“I/O density has increased from eight in a single width to 16 in a double width, and there are more types of I/O, such as those for encoder inputs, motor drives and I/O-Link for communications,” Wadowick says. “To serve in more diverse applications, more machine-mount I/Os are sealed and IP67-rated against dust, oil and water, and extend their range to -13 to 140 °F for normal operations. We keep a close eye on our customers' applications, and adapt to help fill any gaps that appear, such as installing safety I/O components to detect a safe-stop condition about 200 ft up in windmills that are, by turns, colder, hotter, windier and harder to reach than other settings.”

Charlie Norz, I/O product manager at Wago (www.wago.us), agrees that more potential users have been investigating out-of-cabinet I/O in the past two years, especially machine builders and process industry applications seeking to reduce terminations and wiring. “IP67 allows just one I/O block on the machine, so there's only one wire from it to the solenoid or RTD and only two terminations,” he says. “Using a cabinet requires four terminations or more.”

Machine-mount I/O blocks also are becoming more sophisticated and diverse, and so digital I/O points are being joined by data on electrical current, encoders, RTD modules and serial communications, Norz says. “This allows users to do a lot more tasks on the IP67 platform.



Trends in Technology

In fact, our Speedway IP67 PLC can even do high-speed data processing at this device level, instead of the traditional approach of sending it back to a higher-level controller and waiting for a response.”

To help machine-mount I/O protected by IP67 journey further onto equipment in the field, many users employ IO-Link (www.io-link.com), a field-level, intelligent networking method for sensors, actuators and other components on machines and other equipment. “IO-Link is point-to-point, but it requires fewer conductors, and so it simplifies cabling,” explains Frank Latino, product manager for valve terminals and electronics at Festo (www.festo.us). “This means the same four-wire, two-signal cable used for a proximity switch also can be used to control a manifold of 24 valves instead of the complex and costly cables it used to need.”

Festo’s CPX machine-mount I/O and CPI networking system will soon be joined in the U.S. by CTEU, a simple, low-cost, distributed I/O that’s IP65- and IP67-rated.

Many users want machine-mount I/O that can perform distributed motion, safety and specialized interface jobs, according to Corey Morton, solutions architect at B&R Automation (www.br-automation.com). “The way our X67 and X20 I/O modules are connected, their form factor doesn’t matter,” Morton explains. “We can interconnect each randomly, and they all can sit behind a user’s chosen fieldbus interface. What’s new is that digital I/O enables us to handle mixed analog signals, temperature modules, fieldbus interfaces, automatic configuration and web servers.”

Similar to its XV valve control module that connects onto a manifold, B&R has a new motion module, Acopos-Multi65m, which mounts directly onto a motor frame, and has a built-in Ethernet Powerlink hub. “It’s all about giving users more options, whether it’s safety, fieldbus, less programming or web servers,” Morton adds.

Turck (www.turck.us) has also invested in machine-mount, IP67-shielded I/O, especially for multiple Ethernet-based protocols. “This approach makes moving between protocols,

or simply implementing a fieldbus for the first time, plug-in simple,” says Randy Durdick, director of Turck’s network and interface division. “These multi-protocol products are self-configuring, recognizing the protocol of the master automatically, which offers seamless transition to whatever type of Ethernet they need.”

For especially harsh conditions, Turck developed configurable block I/O, which allows users to pick rugged I/O blocks for RFID, analog, discrete, temperature or specialty tasks. These products can withstand extreme temperatures, shock, vibration and environmental protection up to IP69K.

Balluff’s Healy agrees that using Ethernet to access web functions is getting easier for distributed I/O devices. “Previously, we needed a node or IP address for each device added to a machine’s network, but distributed modular I/O means we can hook them all up via one IP address,” he explains. “Basically, we can collect information from digital I/O points, analog channels, controllers and smart devices, and put it through one IP67-enabled, Ethernet component.” Besides its distributed, modular I/O devices, Balluff provides an IP67 machine-mount power supply, so users don’t have to add a junction box every time they need 24 Vdc power.

Likewise, Phoenix Contact (www.phoenixcontact.com) launched its Factory Line (FL) 1605 Ethernet switch to join its Field Line Modular (FLM) IP67 I/O components. “Machine-mount I/O and Ethernet switches with M12 connections mean we can daisy chain IP67-based I/O, and bring multiple functions closer to their sensors and production flows,” says Jason Haldeman, Phoenix Contact’s I/O products marketing specialist. “Also, when you go IP67, it means using pre-built I/O blocks and standard cable lengths, which also simplifies installation.”

Of course, once IP67-rated, machine-mount I/O uses Ethernet to reach the web, then wireless capabilities are sure to follow. In fact, Phoenix Contact already has wireless I/O modules, while its FLM Bluetooth adapter secures its machine-mount I/O signals within 10 m. 



Weidmüller 

More Performance. Simplified. **u-remote.**

Weidmüller's new distributed I/O system is small in size, yet packed with benefits.

- u-remote offers a simple, reliable plug and go set up.
- All connections are pluggable and allow for wire harnesses.
- Individual LEDs for each I/O point.
- Its incredibly fast station bus delivers high performance and real-time process mapping.
- The integrated web server offers remote testing and diagnosis.
- Hot-swappable modules



See u-remote in Action



Let's connect.

www.weidmuller.com/u-remote



Trends in Technology

Arc Flash: Not My Fault

End Users Are Responsible for Keeping Workers Safe From Electrical Hazards, but More of the Onus Is Now on Machine Builders

by Aaron Hand, Managing Editor

Although standards have evolved to help keep workers safe around electrical equipment, tens of thousands of electrical accidents occur each year in industry. According to the National Fire Protection Assn. (NFPA, www.nfpa.org), hundreds of deaths and thousands of disabling injuries occur each year.

Arc flashes are responsible for about 80% of the electrical-related injuries, and can cause severe personal injury and equipment damage when an arc fault superheats the air around it, expanding and creating a pressure wave within an electrical enclosure. Explosions can be as hot as 35,000 °F, and can send shrapnel and molten metal flying out from equipment (Figure 1).

NFPA 70E dictates the precautions that manufacturers should take with their electrical equipment. It provides guidelines on hazard/risk classifications, personal protective equipment (PPE), arc flash boundaries, etc.

Push Back on OEMs

Because it is the factories that are mandated to keep their own workers safe, the bulk of the responsibility falls to them to make sure equipment is properly labeled, the appropriate level of PPE is provided, and workers are properly trained.

As standards tighten, users are beginning to put some of the burden back on the machine builder. “Some customers are requiring us to isolate the high-voltage areas from the low voltage that we would use for PLCs and sensors on the machine,” says Chris Lovendahl, sales manager for Concep Machine (www.conceptmachine.com), Northbrook, Ill. “We are physically separating them so that technicians can debug or troubleshoot the controls system without the requirements for the protective gear.”



HOFFMAN

HOTTER THAN THE SUN

Figure 1: Arc flash explosions can be as hot as 35,000 °F, and can send shrapnel and molten metal flying out from equipment.

Filamatic (www.filamatic.com) in Baltimore also has been separating high- and low-voltage components. “We put logic on one side, power on the other side of the panel,” says Jack Chopper, chief electrical engineer. “That way if you need to troubleshoot the logic, you can open up the panel, no problem. You don’t want to create a situation where somebody’s trying to work on the logic right above a high-voltage area.”

Filamatic takes other steps as well, including data taps and/or Lexan windows in panel doors so they don’t have



Trends in Technology

to be opened as often; interlocks and other hardware that make it harder for users to open panels without thinking; and coordinated fuse protection. A trend toward finger-safe devices also plays a part in improving safety, Chopper says. “It used to be lugs were wide open,” he says, describing how easy it would be to create a fault by dropping a wrench across open copper bus bars.

It’s a growing debate as to just how much responsibility machine builders should take, says Wayne Tompkins, global marketing manager for Rockwell Automation (www.rockwellautomation.com). “What we’re starting to see is that the end user is pushing back on them saying you need to design me a safe machine,” he says.

Lacking Proper Training

Such solutions are increasingly necessary in part because of demands from users who are becoming more aware of

arc flash hazards, Chopper says, but also because of just the opposite: more people servicing these units with less training than their predecessors.

In 2007, the Occupational Safety and Health Administration (OSHA, www.osha.gov) changed how it defines a “qualified person” from one familiar with the construction and operation of the equipment and the hazards involved to one who has actually received the proper training and has demonstrated skills and knowledge.

Unfortunately, the “demonstrated skills” often are lacking, according to Patrick Ostrenga, compliance assistance specialist for OSHA. “Often I hear, ‘Oh, he’s been doing that for 24 years,’” he said during a Plant Services webcast about how to set up an arc flash mitigation program (www.ControlDesign.com/arcwebcast). “But what skills has he had and what training does he have? And oft-times we accept time in place of those real demonstrated skills. And oft-times that leads us to a failure.”

TIME TO SUIT UP?

NFPA 70E standards define the level of personal protective equipment (PPE) needed for a given hazard classification. Figuring out the hazard level, however, can be difficult to do, so manufacturers are sometimes at a loss as to just how much protection each worker needs to wear.

“One of the things that our customers have tried to do is to put the workers in as much PPE as possible so they can be safe,” says Wayne Tompkins, global marketing manager for Rockwell Automation. “But when an electrician has been doing the job for 20 years, and for the first 19 years he did it with just gloves and safety glasses and now he’s being told he has to wear a whole arc suit, he has a hard time accepting that.”

Just as having to shut down the power to equipment can mean a big productivity hit, having to put on all the clothing and gear necessary to protect against the high heat of arc flashes is also seen as a productivity loss. “If we can allow technicians to get at the controls of the machine,

which tends to be low-voltage equipment, without the need for protective gear, we can make their tasks easier to complete,” says Chris Lovendahl, sales manager for Concep Machines. “In this way, we reduce the need for protective gear and that does not reduce their productivity; they do not need the time to suit up.”

It’s not just the time it takes to don the PPE gear that hurts productivity, notes Jack Chopper, senior electrical engineer at Filamatic. It’s also that PPE can make it difficult to get the job done. “You can’t feel things, you can’t hold tools, you can’t maneuver like you could otherwise,” he says. “The equipment is so cumbersome, it’s hard to troubleshoot with all that equipment on.”

By introducing solutions that let workers perform jobs remotely, with doors closed, machine and MCC builders also remove the need for protective gear, either increasing productivity or reducing the chance of sustained injuries.



Trends in Technology

Unpredictable

So machine and panel builders are taking what steps they can to keep arc faults from occurring in the first place. “It’s a two-tiered approach,” says Garrett Potvin, global product manager for arc flash safety products at Pentair Technical Products’ Hoffman (www.hoffmanonline.com). “You want to lessen the number of times an electrical worker has to open a cabinet, and also make it safer when they do have to open it.”

For the first tier, Hoffman has enclosures that include Intersafe data interface ports, which allow access to the programming devices inside the enclosure without opening the enclosure door; and external data pockets, an alternative to placing reference manuals inside the cabinet.

Hoffman’s second-tier solutions include a disconnect switch that cuts the power to most if not all of the components inside when a handle is pulled. The company’s Sequestr solution adds a smaller enclosure on the side of the main enclosure (Figure 2), which isolates power to the smaller enclosure so that workers don’t have to shut the whole system down.

Besides arc mitigation, manufacturers of low-voltage motor control centers (MCCs) have introduced arc-resistant equipment, which addresses what happens if an arc flash occurs when the doors are closed and latched. “An arc flash is more likely if people are working with an open door and the system is energized, adding potential for human error,” says Pablo Medina, product manager for the tiastar MCC at Siemens Industry (www.industry.siemens.com). “Arc-resistant gear will not protect you from that because it will only work when the door is closed. But what people tend to forget is that I can have the door open and something happens and there’s an arc flash there. If it’s severe enough, the explosion can propagate to other units.”

In the event of an explosion, Siemens’ arc-resistant tiastar MCC directs the arc blast, including the heat, plasma and pressure, away from workers.

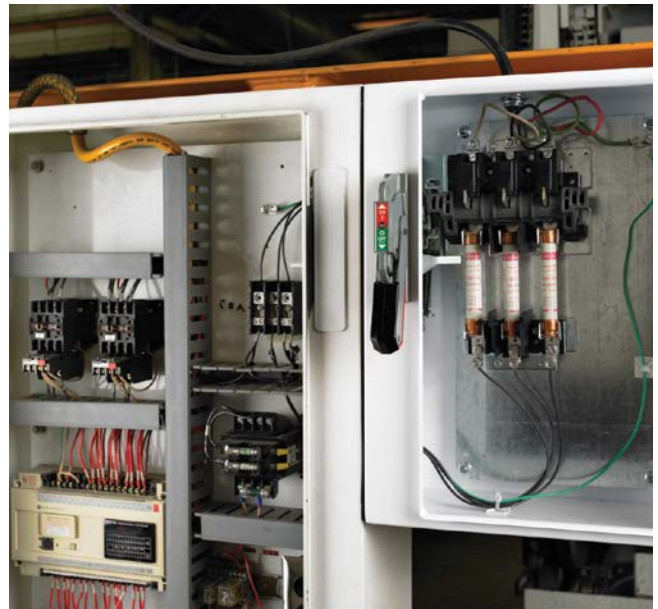

HOFFMAN

POWER ISOLATION

Figure 2: The Sequestr enclosure helps to mitigate arc flash occurrences when working on interior components by isolating incoming power from the main enclosure.

For its latest technology to address arc flash, Rockwell focuses on keeping workers outside the arc flash boundary. SecureConnect removes the voltage from the MCC without having to open the door or go inside the arc flash boundary. “On every MCC unit, there’s a connection that’s made on the backside of a vertical unit that gives it its power,” Tompkins explains. “Without having to open the door, this allows the customer to disconnect the power from the vertical bus.” A remote operator station attaches to the center of the door and allows a worker to perform tasks from 30 ft away.

The range of solutions—whether mitigating or resisting arc flashes—are geared not only toward keeping workers and equipment safe, but also improving productivity. “If implemented properly, you can achieve both,” Potvin says.

The Power of Tomorrow... Delivered Today!



Worlds First Expandable Power Supply

Now, a single power supply can provide 24, 15, 12 and even 5V DC. Eliminate the need for multiple power supplies! Use PS6R as a standalone or snap on a module if your voltage needs change. These compact power supplies even feature an alarm output to ensure notification of problems before they turn into downtime. With full functionality at high temperatures and efficiency ratings among the best available, new PS6R power supplies deliver the power and flexibility you need!

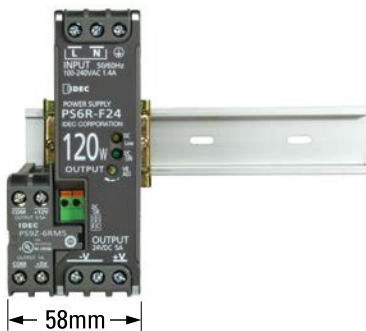

- Most compact power supply on the market
- DC-DC converter modules allow for voltage expansion
- High efficiency with low heat generation
- Class 1 Division 2 and SEMI F47 approvals

Request a sample or in-person demonstration at:
www.IDEC.com/PS6R



Save panel space and cost!





Trends in Technology

Fast Movers

Ethernet's Many Variants Are Just the Ticket for High-Speed Motion Applications.
Get on Board With the One That Works Best for You

by Jim Montague, Executive Editor

All aboard! You might want to catch this train. Ethernet has rolled over the world, and now it's arriving at the last few pockets of resistance, or at least appearing on the horizon.

It's no longer a question of whether Ethernet can handle increasingly higher-speed motion; it's just a question of when and in what applications. But even though you can travel blazingly fast via some Ethernet-based networks, your data packets also have to stay on the rails and stop at the right stations to get where they're going. In machines, trains and on the plant floor, speed is nothing without accuracy. Ease of use helps a lot, too.

"We've been using EtherNet/IP for motion in our palletizers for six or eight years," says Kevin Davis, electrical design manager at Production Automation (PAI, www.palletizers.com) in Montgomery, Ala. "Today, even in our high-speed areas running eight-axis with servos at 80 cases per minute with a half-second cycle time, it's still EtherNet/IP. We just make sure to isolate our high-speed motion from other Ethernet traffic by using an Ethernet module with a ring topology."

Joey Stubbs, North American representative of the EtherCAT Technology Group (ETG, www.ethercat.org), adds, "The days of dedicated networks for motion, I/O and other tasks are effectively over, since all of these tasks can be serviced by one network simultaneously from one controller. Traditional motion protocols don't offer anywhere near the performance, diagnostics, ease of use, configuration and cabling of well-implemented, Ethernet-based protocols. This isn't just due to performance. It's also because machine-level communications now take advantage of consumer-based technologies such as Cat. 5/6 cabling, connectors, transceivers, standard NICs

as masters, standard diagnostic tools, etc. This is instead of having to use special, costly hardware required by legacy protocols. This piggybacking of physical-layer components drives down the cost of systems and increases product selection."

PAI's palletizers have to quickly but gently stack and wrap cases of super-thin plastic bottles, and so they use robot arms and cranes on EtherNet/IP to replace traditional physical diverters.

So, how can machine builders choose the right type of Ethernet and related networking components to satisfy end users who need increased speed and throughput, better handling, increased flexibility and more open networking? Follow a good role model. There seem to be just as many Ethernet-based solutions as users have problems. You just have to get on the right train—and avoid the brawl in the club car.

Slice It or Stamp It?

Basic, vanilla Ethernet wiring and its pure TCP/IP came from IT and office realms, where data was blasted to all parts of the network and speed wasn't as crucial or possibly dangerous as on the plant floor. Ethernet's more recent industrial protocols adopted increasingly intelligent switches and addressing to achieve determinism, and then adjusted their communication methods and rules for increased speed by prioritizing and synchronizing how they transfer data. In general, tightly dedicated Ethernet networking permits greater speed, but means less flexibility. Meanwhile, less-restricted Ethernet enables more flexible communications, but typically runs slower.

Historically, there were two main schools of thought about manipulating Ethernet to serve in higher-speed



Trends in Technology

motion: time slicing and time stamping. To prevent message collisions, boost speed and achieve determinism, time slicing ensures that critical devices and functions are assigned specified time slots to transmit information. A managing node on the network handles time allocation, so the others can transmit without interference when it's their turn. Time slicing is used mostly by EtherCAT, Powerlink, SERCOS III and Profinet Isochronous Real Time (IRT).

The second method, time stamping, is based on the IEEE 1588 standard's Precision Time Protocol (PTP), which defines a method for sub-microsecond synchronization of the clocks in sensors, actuators and other terminal devices on a standard Ethernet-based network or other distributed application. It's used primarily by EtherNet/IP with CIP Sync and CIP Motion. IEEE 1588's basic function is to have the most precise clock on a network synchronize all the others, and then time stamp each data packet moving on the network.

Not surprisingly, the different methods of altering Ethernet for higher-speed motion have led to some arguments. The main debate seems to be between the time slicers and the time stampers. The slicers say that time-stamped Ethernet is basically an Internet Protocol (IP) that's not dedicated enough to truly handle high-speed motion, and that it must run slower because its master device is always on and all data must run through it. However, the stampers counter that time-slicing might be quicker, but it risks losing data because its nodes can't run and communicate when the master device is talking.

Speedier Checks

Bickering aside, to give those food processors all the precise weighing data they need throughout their production lines, Friesen's (www.friesensinc.com) of Detroit Lakes, Minn., designed and developed its Mach-Series and F-Series machines to serve in earlier food manufacturing steps and adapt to a wide range of user requirements.

Mach-Series can run at more than 100 parts per minute, and has two high-speed, precision checkweighers and



WEIGH TO GO

Figure 1: Friesen's washdown-capable checkweighers in its material handling systems use TwinCAT software and EtherCAT I/O terminals and servo drives to adapt to and serve in all areas of food production lines, as well as increase the checkweigher's speed by 31% and reduce downtime by 22%.

a high-speed, in-motion checkweigher. F-Series machines run at less than 100 ppm, and have in-motion checkweighers. Its washdown-capable systems can be deployed throughout food production lines, and its IP69K-rated systems are ideal for USDA-regulated plants (Figure 1).

"In the past, individual adaptation and scaling of the controls could be tricky tasks," says Kari McAllister, Friesen's product development director. "In my view, some of the major controls vendors in this space are too proprietary in nature, and fail to provide interfaces for third-party systems."

To eliminate these roadblocks, Friesen's adopted Beckhoff Automation's (www.beckhoffautomation.com) embedded PC with TwinCAT software and EtherCAT I/O terminals and servo drives to automate, accelerate and simplify its checkweighers. "We sought to process product weights faster and communicate to our reject systems at higher speeds," McAllister says. "EtherCAT can



Trends in Technology

achieve update times for data from 1,000 distributed I/Os in only 30 μ s, including terminal cycle time. Up to 1,486 bytes of process data can be exchanged with one Ethernet frame, which is equivalent to almost 12,000 digital inputs and outputs. The transfer of this quantity of data only takes 300 μ s.”

As a result, EtherCAT and open PC-based controls allowed Friesen’s to decrease machine build time by 25%, cut installation time in half, reduce startup time by 30%, and reduce downtime by 22%. “Also, since Friesen’s began using EtherCAT and embedded PCs, checkweigher system speed increased by 31%, which means we give our users much higher throughput and really differentiate ourselves, too,” McAllister adds.

These gains are no surprise to ETG’s Stubbs. “The highest-performance Ethernet-based protocols meet or exceed the capabilities of even the most demanding real-time motion control tasks,” he states. “The best ones have leftover bandwidth to integrate other functionality, which previously had to be implemented in separate systems, such as ‘non-motion’ I/O, functional safety, data acquisition, and servicing of standard IP devices on the network such as for web thin clients. EtherCAT is capable of scanning 100 servo axes in 100 μ s in one network, which sets it at the highest end of the performance metrics, while undercutting costs, eliminating the need for special cables or special infrastructure components, and allowing users to integrate functions over the same network, such as condition monitoring, functional safety and supporting other protocols.”

Ethernet isn’t practical for the critical tasks of high-speed machine tools, such as controlling spindles at thousands of rpms, but it can help coordinate axes, load and unload parts, manage material handling, and perform other support tasks.

Synch Lots of Axes

Besides enabling traditional speed, Ethernet-based protocols also need to accelerate the coordination required for multiplying numbers of axes, drives and other components.

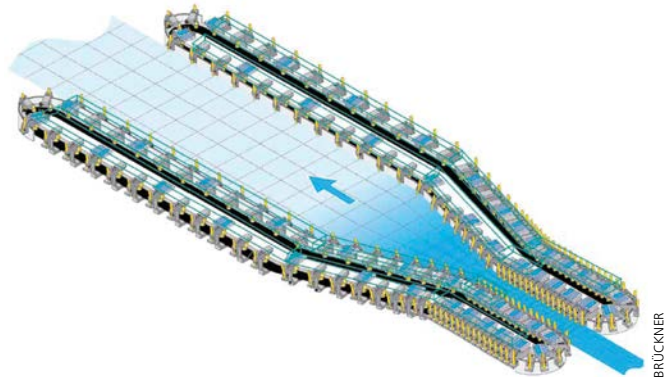

SUPER STRETCHING

Figure 2: Brückner’s linear motor-driven simultaneous stretching system (LISIM) machine pulls and stretches plastic film at 6.6 m/s between two opposing, ring-shaped rail lines, all coordinated by Powerlink, which reduced cycle time to 400 μ s.

For instance, Brückner Maschinenbau (www.brueckner.com) in Siegsdorf, Germany, uses more than 700 clips to pull, stretch and heat set plastic film at 6.6 m/s through its simultaneous stretching system (LISIM) on two opposing, ring-shaped rail lines (Figure 2). The clips are pulled by a moving magnetic field, similar to the railway cars on a magnetic levitation train, which is generated by linear motors with 728 windings.

Current for these 728 zones along the 65 m long LISIM machine is supplied by 384 single- and dual-axis inverter modules in conjunction with 14 power supply modules and drives from B&R Industrial Automation (www.br-automation.com), and they’re all synchronized via Powerlink.

“LISIM’s machine concept is based on linear motors, and we invented it more than 15 years ago, but it’s experiencing a renaissance now because of increasing demand from the packaging and flat panel display industry for film with special properties,” says Günter Oedl, Brückner’s electrical engineering manager for automation and development. “However, the drive technology that we used up to now was getting on in years, and a new proprietary solution would have been difficult and costly.”



Trends in Technology

Oedl adds, “This solution was possible because Powerlink allows precise synchronization of hundreds of network nodes, and simultaneously provides high data throughput. On one hand, we were able to reduce the cycle time significantly—it’s now only 400 μ s. On the other hand, we were able to move large chunks of software from the drives to a central drive controller. This also simplified servicing and software maintenance.” B&R maintains that controlling 728 axes with a 400 μ s update set a world record.

All 398 of the Acopos modules, both power supplies and inverters, in LISIM are synchronized by 12 of B&R’s industrial computers. Each is equipped with three Powerlink cards, which control up to 13 modules. Using another Powerlink card, the computers communicate with each other or with a higher-level industrial computer that runs Brückner’s motion control software. The plant control system, which is responsible for controlling LISIM’s oven, is connected to this industrial PC via a Profibus interface.

Finally, Powerlink’s short cycle times and minimized jitter allowed Brückner to position the zones along LISIM very closely. “The individual zones are grouped in a very homogeneous manner,” Oedl says. “So the error tolerance is significantly less than a millisecond, which was stipulated by the application.”

Robert Muehlfellner, B&R’s automation technology director, adds, “The three fastest Ethernet-based protocols are Powerlink, EtherCAT and SERCOS III, and they’re all fast and reliable enough for high-speed motion. They all can achieve fast update times between sub-500 μ s and sub-1 ms, and they have high synchronization and minimal jitter. There are some technical differences, but their end results are the same, and so they’re all good for 95% of machine applications.”

Closer to Machining?

Aside from axes, one type of motion that Ethernet hasn’t taken on yet is in the CNCs used in machining centers and related tools. Though Ethernet isn’t practical for the

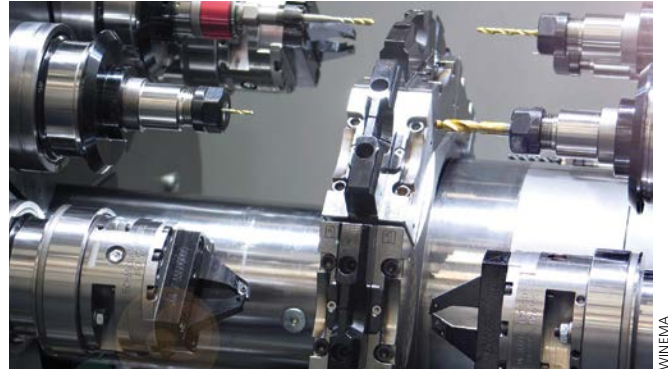

SHORTER CNC SETUP

Figure 3: Winema’s RV 10 Flexmaster CNC-controlled rotary indexing machine for small, 2–23 mm parts uses SERCOS III and a CNC with decentralized intelligent electric and hydraulic drives.

critical tasks of high-speed machine tools, such as controlling spindles at thousands of rpms, it can help coordinate axes, load and unload parts, manage material handling, and perform other support tasks—essentially surrounding the core machining functions.

“Fieldbuses and Ethernet aren’t fast or secure enough for CNC motion, and so we use our dedicated, fiber-optic Fanuc Servo Serial Bus (FSSB) communication line, which runs at 150 MHz, to control servo and linear motors,” says Paul Webster, engineering manager at Fanuc (www.fanuc.com). “Machine tool builders can use Profinet or EtherNet/IP to reach PLCs and control auxiliary devices, such as robotic loading or conveyors, or to reach the enterprise, but not for CNC.”

However, though most CNC functions in machine tools remain as separate islands, Webster says they still added Ethernet ports and fieldbus links over the past 10 years; they download programs with Fanuc’s open CNC automatic programming interfaces (APIs); and they use the XML-based MTConnect (www.mtconnect.org) standard to communicate with PLCs, monitor machine performance, and even download G-code files that the CNC machines use to perform projects.

Similarly, Winema Maschinenbau (www.winema.de) in



Trends in Technology

Grosselfingen, Germany, introduced a CNC-controlled rotary indexing machine in a market usually dominated by cam-controlled equipment. Designed to handle small, 2–23 mm diameter workpieces, RV 10 Flexmaster employs an IndraMotion CNC-based system with decentralized intelligent electric and hydraulic drives from Bosch Rexroth (www.boschrexroth-us.com), which control the machine's 54 CNC axes, including 27 IndraDrive spindle drives. It basically consolidates CNC and PLC tasks into one IEC 61131-3 compliant module (Figure 3).

RV 10 Flexmaster's core consists of a vertical indexing table with 10 clamping stations. In each cycle, the motor-powered table rotates the workpieces to the next station. The machine's rotary indexing principle allows it to process nine workpieces in parallel in each cycle and achieve high throughput.

RV 10 Flexmaster uses SERCOS III, which provides profiles for smoothly integrating both drive technologies, and helps accommodate frequent changeovers. "Previously, cam-controlled machines were unbeatably fast for large-scale series production," says Eckhard Neth, Wine-*ma's* managing director. "However, we've been able to top this speed, and combine it with the advantages of CNC technology for increased flexibility. And combining the HNC with SERCOS III and IndraMotion has allowed us to improve our output by 20% compared to the previously available solutions."

Fast and Familiar Programming

To wrangle those increasingly thin and delicate plastic water bottles and build layers from widely varying case sizes, PAI developed its Hybrid Gantry Palletizer in 2009, and began building it last year, Davis says. Unlike a regular robot arm, this machine and its robots and crane can be thought of as a "Cartesian palletizer" that moves in the usual x, y and z planes, he says (Figure 4).

Besides maintaining high speed and providing softer handling, PAI found that using the eight servos via EtherNet/IP to move, manipulate and rotate the cases also eliminated a lot of mechanical assemblies such as diverters, case



WARP SPEED WRAPPING

Figure 4: Production Automation's Gantry Hybrid Palletizer uses integrated motion via EtherNet/IP to control a dual-head gantry crane and two robot arms with eight-axis servos to quickly, but gently, grab, position and build layers of cases of water bottles for palletizing in a 0.5 s cycle time at an overall rate of 80 cases per minute.

turners and conveyor rollers.

"However, the problem was that the initial programming for this new palletizer was more like using G-code and a teach pendant, which was hard for our customers to learn because they're more familiar with the ladder logic that palletizers usually employ," Davis says. "So we looked for a better way, and decided to use RSLogix 5000 software because we could program it so our users could understand it better and work in a more familiar environment. For example, customers say they can use logic modules in the software's DMAT toolkit to bring in tags for the servos, and easily set up and commission them without having to go to a second software program. Also, the servos' communications are isolated by the Ethernet module, which plugs into the Control Logix PAC, and creates a private network for that EtherNet/IP ring. We also knew this isolation was important because, in the past, we had a problem with a more open network and some users and devices trying to use the same IP address and being unable to communicate." 

RUGGED

Machine-Mount Input/Output Modules



RUGGED Machine-Mount Networking I/O Modules

Ensures the Highest Level of Functionality and Reliability to Your System Devices

Optimize your connections with:

- Industry standard quick-disconnect **M8, M12 Mini 7/8 inch** and **M23** rugged cordsets, receptacles and field attachable connectors – IP65, IP67, IP68 and IP69K
- Rugged **fully potted** actuator sensor distribution boxes with low profile die cast housing
- **T-junctions** are designed to work with two channel M12 ports and when tightened down, they provide the optimal angle for easy handling
- Our **ratcheted design** insures that the connections to the M12 I/O Ports and devices do not back-out when under shock or vibration situations



What's Inside?

- Galvanic isolation between the sensors and actuators ensures more reliable communication, and the ability to withstand extreme electrical environments
- Short-Circuit-proof outputs and die cast zinc housings maximize mechanical stability, functionality and reliability
- Diagnosing devices is made easy through on-board indicators
- Low profile with universal I/O functionality optimizes network planning and commissioning
- Arrangement of M12 I/O ports together with clear labeling make these I/O modules an ideal fit for tight spaces
- Supports EtherNet/IP, PROFINET and PROFIBUS protocols



Try our Latest Low-Profile Design for non-networking applications – Over Twenty Variations to Choose From.

Lumberg Automation
1540 Orchard Drive
Chambersburg, PA 17201

Sales Inquires: **1-800-235-3361**
Technical Support: **1-717-217-2289**

www.lumberg-automationusa.com

Be certain.
Belden.

 **lumbergautomation**
A BELDEN BRAND



Trends in Technology

Mix and Match I/O? Maybe

by Jeremy Pollard, CET

Imagine Rockwell Automation's surprise back around 1994 when the auto industry, immersed in the OMAC push, allegedly said that it wouldn't use Rockwell's new connectivity protocol, DeviceNet, unless it was "open" and available to all.

As a result, the Open DeviceNet Vendors Assn. (ODVA) was formed. DeviceNet is an I/O network that allows various form-factor devices to communicate with a central protocol adapter. The original idea was to simplify the installation of I/O, similar to remote I/O but with smaller concentration.

With a proprietary protocol, Rockwell was counting the bucks, since processor prices were coming down with more distributed control and open PC-based control movement(s). Rockwell's Rich Ryan talked about Rockwell's foray into open control in an ISA session then. One slide said it all: "All control vendors will ultimately become I/O vendors."

I remember a big Ford expansion that used DeviceNet. Cutler-Hammer received the lion's share of the I/O purchase, while Rockwell maintained its grip on the processor and software side. But it was a telling sign. If anyone can develop DeviceNet interfaces, then anyone can use them.

This was between 1995 and 1998. Fifteen years later, we are still somewhat hostage to I/O brands.

The fieldbus market is big. The protocols are varied, and they are all supposed to play nicely with the others. In most cases they do. But as users and OEMs, we should be able to pick best of breed for our applications and not have to pay a king's ransom for the privilege.

Dennis Baca of Ford Motor's manufacturing team wrote in 1997: "With a DeviceNet control system in place..." He didn't say a Rockwell or Siemens control system. A thought shift was underway.

A year earlier, Mike Lane of Wago made a presentation about open I/O options. The message: PLC vendor and I/O (modules, not devices) vendor do not have to be the same. So we move forward, and in most control systems there is an integration of vendor I/O modules from various disciplines.

So why would you want to incorporate Rockwell-,

AutomationDirect- and Invensys-connected I/O in the same control system? Although price is always a consideration, you might think that using an Opto 22 DeviceNet interface is better because of size limitations. Invensys or a similar DCS vendor might have onboard valve control. Festo might have an I/O patch board for pneumatics, which just makes things easier. How about your drive supplier? Does it support any type of direct interface?

A Rockwell strategy paper from the early 2000s indicated the company knew that the behavior of its customers was changing, and were looking for a "roll your own" system. It wasn't surprising to see that the strategy was to entice users with what they want, then convince them to move to Rockwell architecture. A captive customer is the best customer.

Having worked for Rockwell, I get it. I also understand that there are compact cars and luxury cars, and so you have to be careful when you select an I/O supplier you are unfamiliar with. It's your decision whether you introduce various I/O vendors into your ecosystem. It is imperative, however, that you treat that decision seriously.

Support, inventory, availability, reliability and so on are important. Equally important are the specifications on the modules and interfaces themselves. The availability of a specialized module could be a selling point, or not.

Technically speaking, fusing, isolation specifications, removable wiring components and the like could make your choice easier. Maximum current per output module is a real stickler, and has kiboshed many a project.

I sometimes wonder if thinking we have a choice is just as powerful as actually having one. We have come from a proprietary world in automation, into a different proprietary world of "Yes, it might work, but stick with us because we guarantee it."

The benefits of mixing and matching I/O suppliers on the module side can be substantial. Though there can be downside risks as well, the up might overshadow the down.

Use other I/O? Just be informed. Heaven forbid someone claim one thing and deliver another. ☹



Trends in Technology

Terminal Blocks Combine Functions

by Jim Montague, Executive Editor

Maybe it's just the summer heat, but many formerly solid hardware components seem to be shifting shape and functions like a mirage on a highway. For instance, many terminal blocks appear to be taking on new and surprising jobs, and even recombining functions to meet unexpected requirements.

"We've been seeing innovations for panel optimization, mainly to reduce space, and so we've been developing more industry-specific terminal blocks and sensor blocks," says Jessica Colon, product manager for terminals and marking systems at Rockwell Automation (www.rockwellautomation.com). "For instance, where we used to have three blocks side by side, we now can have two in a line and one on top, which means they take up less space on a DIN rail. Also, where traditional blocks used to be 18 mm, we launched our 10-mm block in November, which is a 45% reduction in size."

To preserve even more space and save time, Colon says functions that used to require two or three terminal blocks now can employ just one. "Many sensors have used three-tier, feed-through terminal blocks for 20 years, but for the past few years, fuse blocks with ground connects have been built into terminal blocks."

Michelle Goeman, product manager for rail-mounts, terminal blocks and interfaces at Wago Corp. (www.wago.us), says more users accept and adopt the spring-pressure technology available in its terminal blocks, and that the resulting time savings and reliable connections inspire developers to implement spring-pressure methods in I/O components, relays, fuse holders and other devices. "In fact, we just introduced our Class CC fuse holder for circuit protection in panels, and it incorporates both spring-pressure and intuitive-lever operation, which

shows when the lever opens the spring," Goeman says. "Spring-pressure and its quality connections are expanding to save time in a lot of other markets."

While terminal blocks always will be needed to help deliver power and for field wiring, Howard Minnick, president of Automation Systems Interconnect (ASI, www.asi-ez.com), explains that many of their former tasks have been taken over by other devices. "Over the past decade, we and others developed interface modules (IM), field-termination assemblies and transition modules, which can replace rows of terminal blocks with one cable going into a printed circuit board," Minnick says. "This puts the terminal block's functions into wiring on the board or strip, or even onto a cable with a connector. For example, we had a customer making big, PLC-controlled, overhead ventilators, and he had 1½ to 2 feet of terminal and fuse blocks and relays on a DIN rail. We replaced them with an IM that combined the fuses, relays and connectors, snapped them onto the DIN in one piece, and cut his space used by 50%."

Minnick confirms that two-level terminal blocks with a fuse on top to protect current have spun off and joined three-level blocks with one wire going in, which replace the three side-by-side blocks with separate wires that used to serve devices like three-wire sensors. "Then, sensors gained programmability, and so now we have four-level terminal blocks, which grow out into the available depth in their cabinets."

Vince Lucci, product manager at c3controls (www.c3controls.com), agrees. "Everyone's working out how to make terminal blocks smaller, and fit them into specific applications such as ATEX," he says. "These days we see terminal block systems with really clever interfaces, which are designed specifically to connect to I/O and



Trends in Technology

PLCs. Instead of stacking a couple of blocks together, you now see some machines with dedicated, multi-block systems with specialized marking and jumper straps and accessories. Clearly, the availability of new materials drives these trends. For instance, characteristics of advanced, engineered thermoplastics allow us to fabricate terminal blocks with thinner walls, which can handle higher-rated currents in smaller packages.”

Matt Boudjouk, product manager in the I/O and networking division at Turck (www.turck-usa.com), adds that, as terminal blocks or equivalents are implemented

in new settings, many are finding they need IP67 and other types of protection. “Once you get outside the panel or no longer need conduit, then you’re likely to need molded cables and connectors, and so a lot of terminal blocks need IP67 protection, too,” Boudjouk says. “For example, our Block I/O station has fixed IP67 modules, and can bring I/O or 4-20 mA signals right into the block, while our BL67 modular I/O is more flexible than a terminal block, and operates like the rack I/O on a machine. In fact, next year we’re going to introduce an IP67 PLC for total control outside the cabinet.” 



Getting to a Better—and Cleaner—Source

by Hank Hogan, Contributing editor

Power supplies are growing more efficient and capable. With help, they can better deal with electrical pollution. For machine builders, these improvements promise less expense, better performance and greater reliability.

For example, chipmaker Texas Instruments’ (www.ti.com) latest innovation eliminates components, specifically the optocouplers used for isolation in the feedback regulating the power source output. Optocouplers cost money and can degrade with age, according to Ramanan Natarajan, team manager of TI’s power supply systems applications and solutions.

TI’s approach reads the voltage on the transformer auxiliary winding from the primary side of the power supply. Others have done this, but typically below a 30-W output. Industrial applications need more, something made

possible with TI’s technology.

“We’re able to make this primary side regulation technology support higher and higher power levels in the DCM and CCM [dis- and continuous conduction] modes. We have today reached about 130-W peak,” Natarajan says.

These greater power levels arise from making measurements at specific times and applying proprietary algorithms. These allow greater accuracy of the secondary, or output, side.

At Pepperl+Fuchs (www.pepperl-fuchs.us), noteworthy advances can be found in the company’s diagnostic modules. According to Robert Schosker, power supply product manager team lead at P+F, these modules monitor input and output voltages, temperature, current draw and other data that could signify problems. A high current



Trends in Technology

draw from the field indicates there are some other issues, not with the power supply necessarily, but possibly with the field devices.

Dean Norton, vice president of marketing at Wago (www.wago.us), sees power supplies evolving into products with advanced features, such as the ability to supply substantially more current for short periods of time. Such a capability ensures reliable tripping of circuit breakers or starting loads with high inrush currents. Other improved capabilities involve monitoring. “Monitoring features include an LCD display of the current/voltage output for line monitoring or serial ports for connection to a PC/PLC for trend analysis, alarm conditions, data collection of input/output voltage, current, operating hours, etc.,” Norton explains.

Omron Automation and Safety (www.omron247.com) responded to another trend, according to Dan Nigro, product marketing manager for control components. Panels are getting smaller, so Omron’s recently released, switching power supplies are about 5% thinner than previous products. The efficiency of these latest power supplies runs as high as 93%, up from the mid-70% range years ago.

Rockwell Automation’s (www.rockwellautomation.com) power supplies have been 95% efficient for some time, according to Coman Young, global product manager for power supplies and UPS. He says that power supplies are shrinking, with products now about half the size of eight years ago.

There also has been an increase in current levels. Where before there might have been a 20-A power supply, now there is a 40-A supply. This greater capacity allows a single source to, for example, supply the power to start a conveyor belt.

A beefier source enables power supply consolidation, as do other products. Rockwell, for instance, has a line of electronic circuit protection devices. These reduce the need to have current-limiting sources for sensors and other devices.

“You can still feed those noisy loads or whatever you have that has those coils,” Young says. “I put this electronic circuit protection in series with my sensitive devices, where it will trip if it goes above a set current.”

Power quality is a big push for Rockwell, Young adds. The company has products that mitigate voltage sags, spikes, interruptions and transients.

Power quality is a focus for Falcon Electric (www.falconups.com), a maker of industrial UPSs. The company’s products also do line conditioning, smoothing out voltage, current and frequency swings. That can correct problems arising in a factory, according to Michael Stout, Falcon’s vice president of engineering. He recalls an instance where a large soft drink maker was throwing out entire production runs from time to time. What was going into the power supply was the problem.

“Because of the large three-phase motors operating on the line, when they were starting or stopping, they were producing transients, and the PLC couldn’t handle it,” Stout says. 



Trends in Technology

Network Devices Need Software Support

The Hardware on That Industrial Network Depends on Strong Software to Hold It All Together and Improve Machine Performance

by Jim Montague, Executive Editor

It's always good to increase the scope of your awareness. Whether you happen to be a person or a machine, widening that radius means networking and communicating outside your usual sphere. Lately, a lot of human and industrial networking is being done via the Internet and in the cloud, but there's a point at which it all still depends on wires, cables, managed Ethernet switches, servers and other devices, which software-based interfaces and tools then coordinate.

For instance, Serac (www.serac-usa.com) in Carol Stream, Ill., used pneumatic nozzles on its filling and capping machines, but users eventually requested more flexibility in order to easily change recipes to different products and quickly switch to different containers.

As a result, Serac developed and just released its new range of FC net-weight, filling-capping machines, which use Profibus for tasks such as coordinating load cells for weighing and stepper motors to control nozzles, so they can accurately fill containers from 50 ml to 1 gallon with a variety of products with varying compositions and handling requirements (Figure).

"Our users need to run thousands of different recipes for everything from window-cleaning fluid to potentially foamy mouthwash to very viscous cough syrup, and each of these products has to be handled differently and requires different valves, timing and nozzle settings," says Jean Luc Hostachy, Serac's technical manager. "Now, instead of changing valves, which could take anywhere from minutes to hours, operators just open a program, hit the right button, and the steppers and servos adjust the nozzles for just the right flow for that recipe and its container."

The FC machines employ nine circuit boards that each drive two stepper motors or two load cells for a total of 18 heads, which are connected to a slip ring, and controlled by a PC running proprietary software that Serac wrote for a Windows XP

operating system. It also uses remote I/O modules and servo motors for machine feeding and all of them and FC's heads, PC boards, slip ring and I/O points are on Profibus, which is far simpler than wiring each device separately.

"Having stepper motors on the network doesn't just make the nozzles smarter and easier to adjust, it also makes them easier to clean," Hostachy adds. "We can just flush and be done, which means a lot less cleaning between products. In fact, this easier switchover even means FC can go tankless because it doesn't need a hopper."

Although deploying and networking I/O modules and managed Ethernet switches delivers these and other advantages, it's still important to make sure these new devices don't overload the network, according to Charlie Norz, product manager for I/O systems at Wago (www.wago.us). "Fieldbuses are typically very robust, but as more and more devices get plugged in, signals can degrade, and they might not work as well," he explains. "So a network that only used to talk to PLCs could now have tablet PCs and smartphones trying to communicate with it, and that can add a lot of traffic. This is why it's important to divide networks into virtual local area networks (VLANs) and separate them with firewalls."

Less Cable, More Planning

Because industrial networking's primary commandment in modern times has been to reduce point-to-point wiring, it's no surprise that machine builders, end users, integrators and control/automation engineers have been using twisted-pair Ethernet and fieldbuses and their supporting routers, managed switches and other devices to help limit, design out or combine old-style cabling.

For example, Martin Kolb Steinbearbeitungsmaschinen (www.steinbearbeitung.de) in Bellenberg, Germany, builds



Trends in Technology



FLEXIBLE FILLING

Serac's new FC net-weight, filling-capping machine uses Profinet to coordinate nine PC-boards controlling two stepper motors and two loads cells each to run 18 heads that fill and close 50-milliliter to 1-gallon containers with an thousands of different recipes from window cleaning fluid to foamy solutions up to viscous, syrupy products.

sawing, cutting and polishing machines for natural stone up to 200 mm thick, and recently sought more integrated controls to improve accuracy and cost-effectiveness.

Most of the cutting is done by a bridge saw that's supported by a 15 kW (20 hp) motor, a lifter and adjuster that feed the saw at 1–2 m/min, and a turntable with an up to 90° swivel for complex shapes, which are in turn supported by a series of variable-speed drives (VSDs).

To integrate their controls, Martin Kolb's engineers recently worked with Eaton (www.eaton.com), which recommended its modular PLC and two 100 kHz counter modules to position the stone cutter's axes, while rotary encoders record values. The PLC is networked via CANopen to a 5.7 in. touchscreen HMI, which uses CoDeSys software to create

and program displays that comply with the IEC 61131 standard. Consequently, datasets for the cutter's different motion positions are entered on the touchscreen and sent to the PLC via CANopen, while an Ethernet port is available for further programming and exchanging data via OPC with other systems. Likewise, machine parameters are also entered on the touchscreen, and this is where positions of the axes and the operating and cutting hours are displayed.

"We now can program our entire stone-cutting application with just one software tool," says Thomas Spitz, Martin Kolb's managing director. "All its devices communicate with each other using network variables, and the optional data exchange with other systems via OPC offers our customers enormous possibilities. We've offered a 24 hr service for a long time, and



Trends in Technology

BETTER NETWORK MAINTENANCE

To avoid overloading industrial networks on machines, production lines and facilities, there are several basic steps, according to Wago's Charlie Norz :

- Audit and examine what physical devices are connected to the network.
- Check existing PLCs for errors, and when they send blocks of data, verify they're been received.
- Use software tools, such as Nessus Vulnerability Scanner (www.tenable.com), to find all the Internet protocol (IP) address on the network, ping those addresses, and verify they're from authorized devices.
- Deploy managed Ethernet switches and use them to segment large networks into smaller sub-networks or virtual local area networks (VLANs) separated by firewalls.
- Set up diagnostics tools in the switches to mirror ports, and then use traffic evaluation software, such as Wireshark (www.wireshark.org), to monitor the network.

so we appreciate the remote diagnostics and telecommunications capability that this gives us.”

Coordinating With Controls

Sometimes, instead of moving outward to larger systems, networks grow inward to work closely with individual machines and their controls.

Don Mannon, networking consultant for the eastern U.S. at Siemens Industry (www.usa.siemens.com), says, “Network creep can occur when devices get added without checking how they affect the network’s bandwidth and data throughput. You can avoid this by collaborating with the IT department on a network’s initial design, but Siemens’ TIA Portal can incorporate the appropriate managed switches when it designs a control system, and make them part of the project plan. As a result, the tag database will include tags for the switches along with those for the PLCs and I/O modules. The resulting configuration screen will show the network components and layout in one configuration tool; simple network management protocol

(SNMP) diagnostics will be available; and the SCADA system will show alerts and alarms set up for different thresholds.”

Mannon adds that TIA Portal and Sinema Server can also look at a baseline for overall machine performance, and then examine router and firewalls to filter and prevent any unauthorized packets from coming in.

Reach Out and Customize

Although all the planning and monitoring of networks required by fieldbuses, managed switches and their corresponding software might initially feel restrictive to technicians used to stringing wires or plugging in devices as needed, these standardized components and practices eventually grant more freedom to machine builders and system integrators to customize machines and production lines than in the past.

For example, Vakumix Rühr-und Homogenisierertechnik (www.vakumix.de) in Weyhe, Germany, builds 2–10,000 l mixing and homogenizing machines and production units for liquids from low-viscosity intravenous solutions to high-viscosity products for end users in the pharmaceutical, cosmetics, food and chemical industries, but it recently began integrating controls to help expand its export base.

“The basic design of our machines is the same, so the operating parameters are also very similar, just on a different scale,” explains Robert Mueller, Vakumix’s sales director. “However, 30% of any order we fulfill consists of customer-specific demands, so we have to be able to modify the machine’s design and the operating parameters to meet these demands.”

Consequently, Vakumix installed PACs with distributed I/O, VFDs and HMIs, and networked its panel with Ethernet switches. Among other tasks, these devices and their network, provided by Rockwell Automation, carry out application programming that Vakumix developed for its machines.

“The controller and drives are connected via EtherNet/IP, and supervised by a SCADA system,” Mueller adds. “This combination allows a seamless connection between all sub-systems, and helps reduce development and commissioning times. In addition, this system is ready to support the ISA S88 standard for the process industry.”



Trends in Technology

Sensing Without Wires

Wireless Sensors Can Streamline Production and Improve Reliability and Safety, but Still Need a Few Improvements

by Hank Hogan, Contributing Editor

For manufacturers large and small, wireless sensors solve problems. In applications where their wired brethren pose installation problems, they can streamline and speed up part production by providing valuable data and even improve worker safety. They also help to ensure that parts are manufactured correctly and reliably.

However, reports from the field indicate that cost remains an issue, as do power consumption and data rates. System integration and spectrum conflicts also can be challenging.

In the end, though, what matters is that wires literally can hold manufacturing down. Thus, there's a great benefit to using wireless sensors.

Look, Up in the Sky

“What the wireless buys you is reducing things like cables getting in the way or wrapping around engine hardware,” says Ryan Huth, manager of the assembly special process engineering team at GE Aviation (www.geaviation.com) in Evendale, Ohio.

In 2012, GE Aviation and its partners expect to deliver more than 3,350 jet engines for a mix of commercial and military customers. The company also will refurbish a percentage of the 24,000 engines currently on wing that it had a hand in manufacturing. Each engine can contain as many as 25,000 parts, some of which must be secured using fasteners.

Huth's team develops processes and practices that make this assembly more efficient and cost-effective. Years ago, they investigated and GE implemented wireless sensor-equipped torque wrenches. These wrenches transmit such parameters as torque value, running torque, torque angle, torque rate, fastener location and fastener count. The measurements must be accurate and repeatable to fractions of a lb-in. or fractions of a degree.

Going wireless made the assembly process easier and safer for GE's workers. There are no wires to become entangled

or to cause a tripping hazard. In their work, GE mechanics continuously walk around modules and the engine is flipped through several orientations during assembly (Figure 1).

“It reduces the number of touches an operator makes to a computer interface,” Huth adds as another wireless advantage. “In an assembly shop, anywhere between 30–40% of the touches by an operator actually are interfacing with a PC. So eliminating those steps really is leaning your process.”

GE's products are subject to U.S. Federal Aviation Administration (FAA) rules. Every part and assembly step must be tracked, and this history must be available. Wireless sensors transmit digital data, thereby enabling remote quality assurance checks. This data also enables retrieval of the torque parameters for a given fastener in a particular engine.

Wireless torque wrenches have come a long way, particularly when it comes to batteries, Huth says. Although expensive, the tools are ergonomic, lightweight, and easily handle data transmission needs.

The same can't be said for other GE applications. In particular, there's a need for significant improvement in wireless digital metrology tools. GE performs a series of measurements on sub and full assemblies, checking that they meet flatness, roundness or other dimensional specifications.

Engine tolerances are tight, so the metrology equipment must make accurate and repeatable measurements at a number of locations to 0.1 mil. GE would like to handle this chore wirelessly, but can't for two reasons, Huth says.

One reason is that both contact and non-contact wireless metrology tools are too power-hungry for current battery technologies. Another is that wireless data rates are too limited and latency too high for meaningful measurements of what can be rapidly moving or rotating assemblies. “We collect real-time data at high sampling rates, and we're collecting a lot



Trends in Technology

of information about surfaces,” Huth says. “We need to collect it to a very fine resolution.”

GE’s experience in actually implementing wireless sensors on a plant floor has uncovered various integration challenges. These have included interference between industrial and office wireless networks, with mobile phones and other gear also in the mix. There also have been issues incorporating the collected data into planning and enterprise software.

For wireless sensor products on the shop floor, all of these matters have been resolved, Huth says. But help from wireless sensor suppliers in tackling integration problems going forward would be appreciated.

Some Solutions

Solutions are either here or coming for some of these issues. For instance, vendors and standards committees are working to incorporate features for high reliability, thereby addressing interference and reliability issues. Newer wireless standards such as IEEE 802.15.4 and the ZigBee protocol based on it provide spectrum-interference protection. The former uses a direct-sequence spread-spectrum technique when turning packets into symbols at the transmitter. These are reassembled at the receiver, with data integrity verified through a 16-bit cyclic redundancy check.

Tests have shown this to be robust in the face of electromagnetic interference, even if only one channel is used. However, some vendors running either a wireless networking standard or their own proprietary solution implement additional safeguards.

“There are things like channel hopping (Figure 2), where you’re not just sitting in the same spot all the time,” notes Garrett Schmidt, product manager in the wireless, I/O and network business unit for Phoenix Contact (www.phoenix-contact.com). “You’re moving around the spectrum to try to randomize where you’re transmitting and increase the likelihood you get data through.”

Various techniques also could provide relief for batteries, says Nicholas Butler, platform marketing manager for wireless sensor network products at National Instruments (www.ni.com). “For example, smart sensors could intelligently transmit data only when a threshold is crossed,



UNTANGLED TORQUE

Figure 1: Wireless sensor-equipped torque wrenches made assembly of GE Aviation’s new GENx engine easier and safer, with no wires to become entangled or to cause a tripping hazard.

thereby consuming less power.”

Other technologies would allow sensors to live off the land, electrically speaking. For example, many machines vibrate at either 60 or 120 Hz, depending on the local alternating current. These minute oscillations can be transformed into useful power. “If you know what frequency you’re at, you can tune your energy harvester to capture that,” Butler says. “So the energy-harvesting applications can be structural-health monitoring and machine-health monitoring.”

As for system integration, the industry might in some ways be a victim of its success, contends Todd Hanson, director of wireless solutions at Honeywell Sensing and Control (sensing.honeywell.com). A lot is going on under the hood in terms of the coding and such, but much of this is hidden



Trends in Technology

away, leading to an easy-to-use technology.

“We don’t have a lot of system integrators that are involved right now because it’s actually so easy to deploy and do the pairing process that, in a lot of cases, people are just doing it on their own and they don’t necessarily need any integration,” Hanson says.

Avoid Pressure Problems

While vendors and standards bodies roll out new solutions, existing products are being put to use. At the other end of the spectrum from GE in terms of size sits Waukesha Machine & Tool, a privately held firm with about 20 employees that manufactures special work tooling for machining applications.

Waukesha helps its customers reduce waste by allowing them to hold parts more securely and thereby position them more accurately. More precise machining can then be done, minimizing scrap.

A recent trend is use of large fabricators, with six or seven fixtures shuttling in and out throughout the manufacturing process.

The problem is that the hydraulic clamping systems holding the parts in place can leak and lose pressure over time. Metal shavings and coolants eat away at seals, which makes the loss of clamping pressure and part position a rare but real possibility. If this happens, machines can be down for days and tens of thousands of dollars potentially lost.

“We needed a way to tell the machine, ‘OK, we’re losing pressure in this specific fixture,’” says designer Kyle Spuhler. “We need to put the machine into either a slight hold or an alarm state so that problem can be addressed.”

A wired solution would have presented multiple problems. In machining applications, wires encounter sharp chips, coolants, blasts of air, and constant flexing. All of these eat away at protective insulation, increasing the possibility of a short. Also, wires can become entangled. Another possible solution involved a mechanical pressure check. However, this could be done only at specific locations, requiring fixture cycling in and out.

After evaluating alternatives, Waukesha turned to wireless pressure sensors from Electrochem (www.electrochemsolutions.com). The sensors transmit information every three

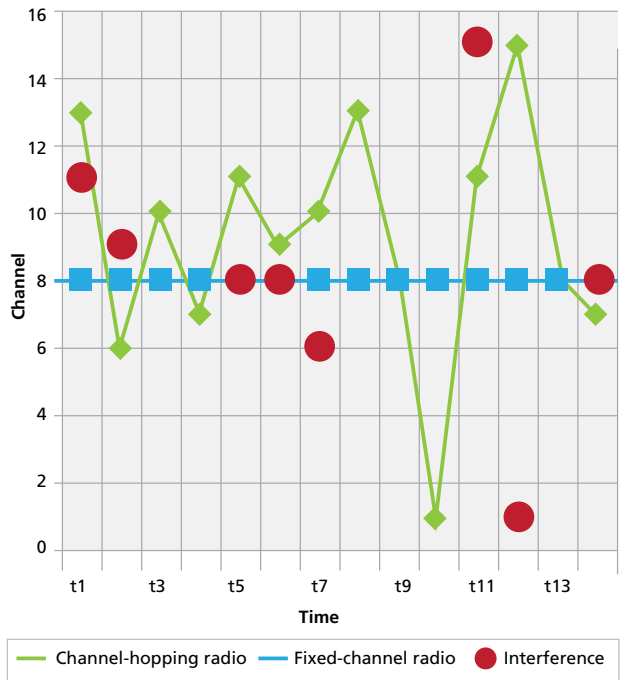

HOP AROUND

Figure 2: Radio technologies that use channel hopping are typically more robust in environments with high interference levels.

seconds, three minutes or as needed, Spuhler says.

The devices have their own custom-designed battery, he adds. These are high-rate, spiral-wound cells using proprietary enhanced bromine chloride technology that delivers superior restart, pulse capability and dependable performance over wide temperature ranges and discharge rates, according to Electrochem. The sensors use the ZigBee standard at higher power levels that extend range. Distances to 1,200 m are possible with a 100 mW output from the base station.

At a few hundred dollars each, wireless pressure sensors are much more expensive than a mechanical equivalent, which could cost less than \$10. But in the long run, the process, the product and manufacturing security will all be improved and catastrophic failure caused by pressure loss eliminated. Benefits like these could apply in other situations, which points to the future for wireless sensors. ■

PHOENIX CONTACT



Back to Basics

Think Global, Connect (Sometimes) Local

by Hank Hogan, Contributing Editor

I/O connections come in two flavors. There's the hard-wired, local variety and the distributed, remote type. For machine builders, deciding which way to go basically comes down to the number of nodes and the distances to them. Generally, both users and suppliers will tell you that machines with more I/O points that are further away tend to come out ahead by employing a distributed, remote connection strategy.

"If you have a smaller volume of I/O, and they're not spaced that far away from the control cabinet itself, then sticking with the traditional parallel wiring, everything wired back to the PLC, is probably the most cost-effective option," says Jason Haldeman, lead product marketing specialist for I/O and Light at Phoenix Contact (www.phoenix-contact.com).

The location of this dividing line for the number of nodes is fixed by two constraints. The first is a hard number. "PLCs have only so many connections available inside their chassis," Haldeman says. "If the number of I/O points causes that to be exceeded, one option is to go to an expansion chassis, but those tend to be expensive." He adds that, in situations such as these, it might make sense to go with distributed I/O since it sidesteps chassis limits.

For the second factor, I/O count, the crossover point has to do with cost. A hard-wired approach brings everything back to a control panel, which tends to be centrally located. There's a cost associated with such wiring, says Joe Wenzel, regional marketing lead for Rockwell Automation (www.rockwellautomation.com).

Typically, a hard-wired approach requires landing six terminations per I/O point. Each termination involves stripping wire and inserting it into a termination block, a process that's not free.

"A lot of customers will say it costs them \$10 per point, for

example, to do that," Wenzel says. "So every wire I do here could be \$60 or some number. And there's also the risk of miswiring with a higher number of terminations."

In contrast, remote I/O often requires landing only two terminations. It's better yet to use a sensor hung directly on the network because this requires no standard-wired connections.

At some number of nodes, the savings from wiring alone will tip the scales toward a distributed approach. A node cluster also can be an argument for using distributed I/O, at least in selected areas.

"If I have a distant machine location where I have areas with high densities of I/O, then it would make sense to put a distributed I/O system out in those areas," says Rockwell Automation's regional marketing lead, Scot Włodarczak.

Any wiring expense might not be a one-time event, and that could make remote I/O more attractive, comments Thomas Edwards, senior technical advisor at Opto 22 (www.opto22.com). Very large machines might be assembled once by the system builder, tested and then shipped in pieces to the customer. Once there, the machine has to be reassembled and checked out again. What's more, after initial installation, a machine could be moved as factory floors are modernized or expanded.

"If the machine is big enough that it would get shipped or moved or even moved around the plant in pieces, making the connections becomes a real pain in the neck," Edwards says. "It's a big expense, and it's a very common point of failure, probably a much higher failure rate than any of the electronics. If you can eliminate that, you have a more reliable and less expensive machine."

As for distance, longer runs tend to favor distributed I/O. All signals lose strength when traveling down a wire, if for no other reason than the resistance of the wire and the resulting voltage drop. That loss is more pronounced as data rates go



Back to Basics

up due to the rapid switching of the signal. Thus, there's a need to periodically boost the signal. Ethernet-based technologies offer very inexpensive ways to do this. About 100 meters of wiring can run between signal-boosting switches.

Johnston Hall, commercial engineer for PLCs, networks and distributed I/O at Omron Automation and Safety (www.omron247.com), notes that the decision to go remote might be easier if other devices are present. Some of the possible devices that might be running remotely on a network connection in any case could include bar code readers, ID tags, servos, motors and even vision systems.

"If you have to communicate to them anyway, you need remote I/O," Hall explains. "It's another reason to think that putting the digital I/O on the same cable might make sense."

One past reason that made sense to go with local I/O no longer applies, says Kurt Wadowick, I/O and safety specialist at Beckhoff Automation (www.beckhoff.com). Local, hard-wired connections once were significantly speedier than remote, distributed technology, but that is no longer true if the right connection technology is used.

"With EtherCAT, the data is organized right at the I/O module to the exact process image the PLC program needs, and is

transferred directly to the controller's memory without requiring any effort from the controller CPU," Wadowick says.

He adds that typical update rates possible with such an approach are 200 16-bit analog points in 50 μ s. Some 256 digital I/O points can update in 12 μ s.

Finally, it's important to remember that the question of local versus remote is not "either/or" but "and." All PLCs have some provision for local connections and most installations make use of the capability. Thus, the majority of machines have a mix of local and remote I/O connections, says Kevin Wu, distributed I/O product manager for industry and factory automation at Siemens Industry (www.usa.siemens.com)

The push to implement a distributed, remote I/O system happens when connections grow to be too numerous or runs too long. Remote I/O also might be implemented if a retrofit is done to bring in safety features, but everything begins with the local connection.

"A remote I/O station only happens when there's a local I/O station," Wu says. "Local always comes first because that's basically the location that all your field devices are closest to. As you expand the number of devices, that's where you have to consider a remote I/O rack." **cd**



Make Circuit Protection Easier

by Aaron Hand, Managing Editor

Besides complying with the UL 508A safety standard, which outlines circuit protection for industrial control panels, circuit protection is essential for reducing downtime and finding the root cause of failures in order to maintain consistent production flow. After decades of manufacturing, all industries still struggle to troubleshoot electrical equipment effectively, according to Stephen Starr, automation product marketing and sales specialist at E-T-A

Circuit Breakers (www.e-t-a.com).

In some ways, this is truer today than ever. "With the most experienced workforce in the last 50 years beginning to retire, a lot of experience will be walking out the door with very little young talent to backfill the needs on the plant floor," Starr says.

Tony Locker, manager, product management for Littelfuse (www.littelfuse.com), agrees. "As plant staffs continue



Back to Basics

to shrink, younger workers often don't have the benefit of working side by side with experienced workers who truly understand electrical protection," he says.

Circuit protection suppliers are doing more with the technology to not only make it work faster and more effectively, but also make it easier for plant personnel to detect and resolve electrical faults.

For example, current-limiting fuses and circuit breakers will open at least 12 times faster than a typical non-current-limiting circuit breaker, which can take up to six ac cycles to open under short-circuit conditions, according to Locker. Current-limiting devices, on the other hand, can open within the first half cycle of a fault (8.3 ms). "Its fast action limits the amount of current that can flow through the circuit and reduces the destructive energy of a short or arc-flash," Locker says.

Once a fault occurs, finding which fuse has opened typically requires poking around an energized electrical panel with a tester. "Besides the danger, this process prolongs downtime," Locker points out. Indicating fuses, on the other hand, have a dark spot that appears when the fuse opens; and indicating fuse holders point out open fuses with a bright neon lamp or with a signal to a PLC.

UL 508A requires a short circuit current rating (SCCR) on any components in the electrical power distribution path. The required SCCR, which is the maximum short circuit a component, assembly or equipment can safely withstand with a specific overcurrent protective device, is changing the way machine builders and end users are looking at circuit protection. "I would say that we see customers moving toward using branch circuit protection devices that make accomplishing the overall panel SCCR easier," says Michelle Goeman, product manager,

terminal blocks and electronic interface for Wago (www.wago.us).

Using fuses rather than circuit breakers makes accomplishing panel SCCR more convenient, according to Goeman. "Because fuses all have a standard trip curve, manufacturers can test their components with a particular fuse and achieve a short circuit current rating with all fuses of equal or lower ampacity rating that meet or exceed the trip curve. However, a component that is tested with a circuit breaker to achieve an SCCR may only be used with that exact circuit breaker—it is much more limiting."

The need to change current levels in the field during the commissioning or installation phase has become a new parameter at the design level. "Breakers need to move towards the flexibility of a fuse, while maintaining the integrity of a breaker," says E-T-A's Starr, who adds that the need to change current levels in the field during the commissioning or installation phase has become a new parameter at the design level.

Starr maintains that solid-state electronic circuit breakers, which detect both overcurrent and short circuits with alarm outputs and remote reset inputs, offer the best protection for field I/O devices when a switch-mode power supply is used. Flexibility and interchangeability will make those circuit breakers even more useful in the field.

"We have developed a breaker combination that will allow for the current rating to be field-modified and allow for a technology change to suit the needs of the load protection requirements, from thermal magnetic to electronic and vice-versa," Starr says. E-T-A plans to release the product later this year. 



Back to Basics

Analog I/O Serves Real-World Control

When Users Require Large Chunks of Complex Data and Need It Fast, They Still Turn to Analog I/O Hardware

by Jim Montague, Executive Editor

Sometimes ones and zeroes in their tiny time slices aren't enough. Sometimes a manufacturing process, machine application or production line just needs a nice, fast, old-fashioned, undivided analog signal.

Of course, most of today's signal data moves from sensors through digital I/O components, following the lead of digital networking and higher-level computing functions, which have reached ever further down into the device and I/O levels in recent years. Still, the visible world remains an analog environment, so temperature, power, pressure, flow and other physical variables must sometimes be measured closer to the undiluted form in which they were generated—and not in the series of snapshots in which digital data is typically captured and transmitted.

Analog Update

Integrated Industrial Systems (www.I2S.com) in Yalesville, Conn., builds cold rolling mills and control systems for ferrous and non-ferrous applications and long has used PLCs to control its mills, as well as a gamma gauging system to accurately control metal thickness. To update its gauging system's outdated hardware and software, I2S required a custom measuring device with accurate analog I/O and advanced processing to convert sensor signals into accurate thickness measurements, but the usual PLCs didn't have enough speed and signal processing capabilities.

So I2S adopted CompactRIO programmable automation controllers (PACs) from National Instruments (www.ni.com), and used NI's LabVIEW graphical programming tools and real-time function blocks to program its field-programmable gate array (FPGA) and real-time processor. Each rolling mill contains three networked CompactRIO systems, which are intelligent nodes that communicate

with myriad controllers using Modbus/TCP, TCP/IP and UDP protocols. The three CompactRIO systems are connected via Ethernet and use UDP Ethernet messaging protocol to transmit thickness measurement calculations in less than 20-ms intervals.

"CompactRIO's analog I/O and digital I/O modules connect to the mill's gamma-based thickness sensors, and its embedded FPGA allows us to customize the I/O rates and synchronization," says Clark Hummel, senior development engineer at I2S. "The data received from the sensors then is processed in the real-time processor using real-time, floating-point function blocks to convert data from the sensors to accurate thickness measurements. LabVIEW real-time performs deterministic, advanced logarithmic processing on the data received from the FPGA to calculate thickness measurements. The CompactRIO systems perform all of the I/O and signal processing in the FPGA and real-time processor, and transmit high-accuracy thickness measurements to connected PLCs without slowing down existing PLC control loop rates. With this performance, we were able to add this custom measurement and analysis for our gamma-based sensors without compromising our control rate speed."

More, Faster Signals = Better Control

Similarly, test-rig builder Sitia (www.sitia.fr) in Nantes, France, has to deal with a widening range of I/O signals required by the equipment it builds. It manufactures standard and modular, turnkey, automatic test rigs for simulating mechanical, physical, hydraulic, pneumatic, climatic and electrical parameters. These devices are used by industrial and technical laboratories to test material fatigue, quality measurements and parts characterization, hardware in the loop (HiL) and quality in the automotive,



Back to Basics

aerospace, railway, bicycle, wood and furniture, civil engineering and other industries (Figure 1).

Tests are defined by the equipment users, and Sitia's engineers design rigs for each based on a precise spec sheet, which they and the customer develop together. Lately more clients request machines that go beyond meeting their test requirements in order to give them more flexibility to exchange sensors, actuators and related I/O points for subsequent tests.

"Industrial laboratories need machines tailored precisely to their tests," says Fabien Arignon, Sitia's managing director. "However, at the same time, they also demand independence, which means they don't want to constantly rely on their supplier if sensors or actuators have to be added to or removed from the machine, or if settings have to be changed and parameters entered. We had to come up with a solution that would allow us to offer this flexibility."

These considerations ultimately led Sitia to the concept of a modular, universal test rig. "Modularity and the standardization of components form the matrix of our new machines," Arignon says. "This modularity exists on several levels and extends from the mechanical components to the controller. With respect to the controller, test systems differ from most other automation applications in that they encompass a large number of sensors and actuators in various versions. On the one hand, we wanted a higher degree of modularity, but on the other, the configuration of the hardware and software had to be simple to adapt."

As a result, Sitia selected EtherCAT analog I/O terminals from Beckhoff Automation (www.beckhoff.com) because they acquired measured values with 0.01% accuracy, enabled the modularity and scalability of Sitia's equipment, and covered the wide range of I/O signals the test rigs needed to handle. Also, Sitia uses Beckhoff's TwinCAT PLC as the new test rig's universal programming and automation software and NI's LabVIEW software as the



BECKHOFF AND SITIA

TEST RIG TERMINALS

Figure 1: Sitia uses analog I/O terminals to help build modular, flexible universal test rigs that its users can configure independently, including a test system for gearboxes (above) and a load simulator for testing seats (inset).

operator interface. Data is exchanged between TwinCAT and LabVIEW via Beckhoff's communication DLL.

"With EtherCAT terminals, we can acquire measuring signals directly in the standard I/O system, which considerably simplifies the control architecture," Arignon explains. "In addition, we and our customers know LabVIEW well, and it's particularly interesting for us because of its software libraries for the visual representation of measurements in diverse formats, such as digital or dial displays, curves, tables, etc."

Consequently, combining analog I/O with new software and networking helped Sitia achieve its vision for a modular, universal test rig and enables its users to configure their machine independently. "I/O reserves are provided, so users can add or change sensors and actuators, as well as the necessary measuring modules in their machines, depending



Back to Basics

on needs,” Arignon adds. “The changes are specified in a table under LabVIEW and passed on to TwinCAT. Special knowledge isn’t required on the part of the user because the software is easy to use.”

Black Boxes Join Networks

While analog I/O were traditionally used as stand-alone devices in process applications from oil and gas to textiles, specialized components allow them to do more varied jobs in more integrated, diverse settings, according to Kurt Wadowick, Beckhoff’s safety and I/O specialist. “Analog I/O specialty modules now can do power monitoring at the terminal level and examine voltages, currents and analyze three-phase power,” Wadowick says. “This is possible because the cost of converting chips inside I/O modules is down, and their availability is way up. Also, analog I/O modules have more channels available now, and they have better integrated circuitry that’s come a long way in recent years.”

While most analog I/O terminals still only cost a couple of hundred dollars on average, Wadowick adds that their more-capable, less-costly microprocessors allowed them to evolve from stand-alone black boxes with proprietary software to more-capable and connected devices that can handle more different jobs. “This is why we brought analog I/O into our system, so we can eliminate the black box and make its functions less costly to implement,” he explains. “EtherCAT’s high bandwidth can work with a high-speed strain-gauge terminal, which used to run stand-alone in a weigh-scale application, and instead use analog I/O devices such as our EL3 to do readings and pass along data to the overall system. Specialty analog I/O terminals can check voltage and current inputs and perform condition monitoring, such as using an accelerometer to establish the baseline frequency on a large bearing, and then using a vibration terminal to pick up bangs and knock as it wears. In



ROCKWELL AUTOMATION AND R & B PLASTICS

FOREVER BLOWING BOTTLES

Figure 2: R&B Plastics blow-molding machines use analog I/O modules to achieve tight parison control and maintain high-volume production with minimal cycle times and waste.

classic voltage measurement, as analog I/O terminals can see finer and finer increments of voltage changes, it allows users to do more and more precise control.”

Retrofit and Revive

Ironically, bringing in old-style analog can improve the performance of machines with seemingly more modern digital controls. For example, R&B Plastics (www.rbplasticsmachinery.com) in Saline, Mich., builds continuous-extrusion, blow-molding machines with wheel-and-shuttle and calibrated, water-cooled neck finishing for high-volume output. They’re designed to accommodate multiple parisons, multilayer coextrusion and in-mold labeling of 12-ounce to 2.5-gallon containers (Figure 2).

Tight parison programming and control are needed to maintain production, reduce cycle times and achieve optimum wall thicknesses of continuously extruded profiles,



Back to Basics

but still minimize raw material waste. Besides programming comparison controls, R&B also offers its users scalable control retrofits of their parisons.

To meet its high-speed, high-volume goals, R&B's blow molders must employ equally high-volume data processing. So R&B uses ControlLogix Fast Analog I/O modules from Rockwell Automation (www.rockwellautomation.com), which use on-board data-archiving to increase system throughput by reducing overhead required to collect data. This module also has four archiving inputs and two outputs, which generate fast sample rates, while decreasing backplane traffic for optimized system performance. In addition, Fast Analog lengthens the time between I/O data transfers, relieving R&B's controller of burdensome information and decreasing process disruptions. The analog I/O module's data archiving also helps R&B's users make sure their quality expectations are being met, even though their applications are increasingly complex and fast. Finally, its data archiving feature allows for configuration options, such as data type, tag generation and establishing connection between the controller and the high-speed analog I/O module.

Going System- and Plant-Wide

Just as analog I/O can bring faster, more holistic signals from an individual machine, it can do the same for overall production lines and facilities.

Filtros Tecfil (www.tecfil.com.br) in Guarulhos-SP, Brazil, manufactures 5.5 million automotive filters per month and exports to more than 120 countries. However, until recently, it controlled production data manually with paper forms and Excel spreadsheets, and machine stoppages were communicated through a synoptic panel that didn't provide enough data on time and cause.

To reduce its downtime, Tecfil brought in system integrator GMR Consultoria, which recommended its two-

part GMR Olho Vivo solution to acquire analog and digital signals via improved sensors and wireless networking on its filter-assembling machines. The first section includes a rack with an 18-channel, isolated digital I/O with a Modbus TCP networking module and an eight-channel, isolated analog I/O also with Modbus TCP, both from Advantech (www.advantech.com). This hardware acquires data and passes it to a central server, where the second section, GMR Olho Vivo software, analyzes and converts it to usable information, transmits it to displays at strategic production points and integrates with ERP/ MRP managerial systems.

Each display can show different information, so users can see and act on relevant data for their area. The system administrator also can receive data on instability and equipment failures via email or text messages. Tecfil reports its new analog and digital I/O and analysis has saved time by automatically gathering data and recording event times, so technicians can focus on root-cause analysis, identify priorities and develop actions plans much faster.

Likewise, Advantech reports that these analog I/O can help control and coordinate the larger numbers of CNC machines now running in many plants, easily join and participate on existing networks, and help managers quickly understand abnormal events, restore normal functions faster and reduce downtime. While a PLC can acquire CNC signals, this option can be costly and result in poor data immediacy. In this CNC scenario, the digital I/O module can collect all switch data from a plant's CNC machines as states change, while the analog I/O detects current changes on the machines to help control their workloads. Using an Ethernet interface, both modules can be integrated into a plant's original network architecture and transmit on-site signals to its overall distributed network control server via Ethernet switches. □



Back to Basics

The Right Cable Connection

by Hank Hogan, Contributing Editor

Just as clothes can make the man, cables can make—or actually break—the machine. The wrong wiring can cause electronic drives to prematurely fail, lead to regulators shutting down machines, or result in the loss of important data. On the other hand, the right cable can allow an automation solution to work as designed.

The proper cable choice begins with a few fundamentals. The first is application specific: “Is it going to be a power, control or signal?” asks John Gavilanes, director of engineering at cable manufacturer Lapp USA (<http://lapp.usa.lappgroup.com>). “That would dictate what cable you’re going to be using.”

The second basic requirement is the ability to function reliably in the often harsh environment of a plant floor.

The third broad necessity is to satisfy regulatory requirements and customers, such as using a specific color-coding for cabling based on its voltage.

Fundamental Focus

With regard to the basic function, a key difference between power and signal wiring applications has to do with the voltage and current specifications. Control or signal wiring typically sees only a few volts, and need only support milliamp currents. Power wiring, in contrast, might have to handle hundreds of volts and amps of current. Thus, the gauge of the wiring could be 14 or less, meaning the diameter of the conductor is 1.8 mm or larger. Signal and control wiring, on the other hand, might be as small as 24 gauge or 0.6 mm.

Power and control-signal wiring were once quite distinct. That difference is becoming blurred due to the increasing use of variable-frequency drives (VFDs), which change speeds in response to a varying input voltages and current waveforms.

The result is a solution that can be more responsive and more energy efficient than a traditional, single-speed drivem, but it does demand more from the cabling. Waveforms could be traveling down the wire at megahertz rates, with voltage swings from zero up to hundreds of volts, and currents ramping through the complete range. What’s needed is determined by the motor. A 5 hp motor, for instance, might demand 7.6 A and 460 (3 ph) V with switching at 20 MHz.

Sending such a waveform down a wire can have various effects. Some can show up in the drive itself, if the cable is not up to the task. These waveforms generate high-frequency ground currents in the return path. If the cable isn’t constructed to deal with this, the current will find other ways to ground. For instance, this could be through the drive bearings, leading to arcing that pits the bearing races.

“The bearings will eventually be so worn that premature bearing failure will result,” says Isaac Muller, applications engineer at cable maker Nexans (www.nexans.com). “That’s usually a good first sign of a VFD cabling issue.”

Environmental Concerns

Outside the drive, varying voltages and current at a high frequency can create significant electrical noise. “A lot of these Ethernet cables are installed very close to drive systems, and in most factories drive systems are often the single largest source of noise,” says Peter Cox, industrial project manager at cable maker Belden (www.belden.com).

The solution involves installing shielded cable, with conductive sheaths protecting the wiring. The need for such shielding might become apparent after the installation and use of VFDs.



Back to Basics

Resistance to electrical noise is an example of the basic need for wiring to function correctly in a given environment. Other common factory-floor issues involve oil, temperature extremes or crushing force. Oil resistance is a particular concern, and is a good reason not to use standard Ethernet cable. The insulation of such cables is typically not oil resistant. In fact, it could be oil-soluble.

Certain environmental issues arise from the automation solution itself. “For instance, some applications require that cable flex and bend, perhaps with a twisting motion thrown in,” Cox says. “In such situations, the changing geometry and distance between conducting strands can lead to signal attenuation. This happens because the impedance changes, resulting in reflections. Testing has shown return loss margins from such effects can be as high as -5 dB. Belden’s solution is to use its Bonded-Pair technology, which ensures the distance between individual strands does not vary even as the cable is flexed, coiled, compressed or twisted.”

Satisfy the Regulators

A different kind of solution is needed for regulatory requirements, the last broad basic specification that cabling must meet. Often this involves product ratings with regard to voltage, suitability for use in a hazardous or dangerous setting, and flame resistance. The latter, for instance, could involve exposing cable to flames for anywhere from 30 seconds to 40 minutes, with the requirement being that the wiring either not catch fire or only suffer damage over a limited distance. Such testing can’t be done solely by the wiring manufacturer.

“Have they been evaluated by a nationally recognized testing laboratory?” asks Eric Bulington, chief engineer for wire and cable for Anixter (www.anixter.com).

Organizations such as Underwriter’s Laboratories

(www.UL.com) in North America and Europe’s International Electrotechnical Commission (www.IEC.ch) can have thousands of ratings that apply to wiring and cable. There might be dozens of listed types of wiring specified. There also could be another class of wiring designed to be used on a machine or between its components that enables the end product to meet requirements.

The waveforms generate high-frequency ground currents in the return path. If the cable isn’t constructed to deal with this, then the current will find other ways to ground. This could be through the drive bearings, leading to arcing that pits the bearing races.

At times, the regulatory and environmental specs of wiring overlap, according to Katina Kravik, CEO of cable maker Northwire (www.nothwire.com). For instance, wiring that goes into and out of a wet location has to meet designated approvals, a case where a specific rating is needed due to an environmental conditions. Another example is RoHS compliance. Here, lead use is restricted.

Ratings can be complex and satisfying them costly, with testing done by a host of different nationally recognized laboratories. The output is often a report and certification that an inspector will go over in order to ensure that a system can be operated.

However, sometimes not meeting regulatory requirements isn’t hidden. For example, a standard requirement for all wiring is that it be a certain color to signify voltage level or other characteristics. Failure to meet such basic specifications is easily detected, says Andy Pringle, North American OEM commercial manager at Rockwell Automation (www.rockwellautomation.com). “The local inspector could say you can’t start up because it doesn’t meet code,” he says. 



Back to Basics

High-End Protection for Low Power

by **Jim Montague, Executive Editor**

Just because some circuits carry less juice doesn't mean they don't need and deserve protection. In fact, 24-V and other lower-power circuits are proliferating in devices and networks, and so are the tools and smarts to safeguard them. As always, the trick is to apply them appropriately for the most benefit.

"Circuit protection is a mainstay of 24-V products, but besides breakers and fuses, we have increasing use of electronic circuit protection (ECP) software and intelligence," says Aaron Henry, North American market manager for Murrelektronik (www.murrelektronik.com). "This is because breakers and fuses don't always work as well as they should when protecting low-voltage components."

Breakers and fuses are older technologies, Henry reminds us. They look for heat to identify current-resistance and other problems, and they have to be replaced frequently. "However, electronic circuit protection can be turned on and off remotely, it keeps people out of potentially hazardous cabinets, monitors entire circuit current levels, handles current inrushes better and immediately notifies users of short circuits without having to go through the usual breaker conditions of resistance and heat. ECP is really the next generation of breaker and fuse functions," he says.

Over the 10 years Murrelektronik has been building ECP devices, Henry reports, it's expanded into broader current and voltage levels, and developed its Mico products, which are similar in shape to breakers, have adjustable current settings and can replace 12 traditional breaker styles. The latest Mico product is a 48-Vdc solution. "The microprocessor and software in an ECP component monitors current, and as its panel approaches 90% of a pre-selected current level, it gives a warning. If

the current goes beyond that level, it reports if there's a fault or overload condition, isolates that circuit and cuts the voltage. ECP is a relatively new technology, so we're excited to bring these new products to market with more functionality."

Traditional breakers can monitor for short circuits or over-current conditions, but not both. However, ECP can perform both tasks. "Many circuits are getting more sophisticated and becoming involved with higher-level fieldbuses, and ECP capabilities can assist these changes, which is improving its acceptance," Henry adds. "In the U.S. markets, we still have a lot of education to do, but there's a clear trend to toward avoiding contact with potentially hazardous cabinets and removing consumable components from inside them. Everyone is becoming more aware that they need circuit protection at low-voltage levels."

Mark Stremmel, U.S. systems manager for Turck's (www.turck-usa.com) Engineered Packaged Systems group, adds that, "Old-school system design and circuit protection was regimented and strict, and we used circuit breakers on the load side of the 24-V supply and on the line side as well, so users could isolate power, test and do maintenance. Breakers would be distributed for all PLCs and HMIs, but as OEMs competed more, many no longer did it because it wasn't required by UL508A."

Stremmel adds that almost all dc power supplies have gained some form of electronic short-circuit protection built into their circuitry over the past 10 to 15 years. "If they read an over-power or short circuit condition, then the output side shuts down until the load or short is removed," he explains. "However, because of this electronic monitoring and protection, many users and OEMs



Back to Basics

now think they don't need circuit breakers as much on the load side."

While most control systems and circuits also migrated from 120 Vac to 24 Vdc during the same 10 to 15 years, Stremmel reports Turck believes breakers are still essential in many settings. Turck offers circuit protection in all its I/O product categories, including on-machine block, on-machine modular, in-panel block I/O and in-panel modular, which all communicate via multiple Ethernet-based protocols.

"Our view is that if you've got a PLC, HMI, Ethernet switch or other dc device such as field power, then you don't want all of them to go down when one shorts out," Stremmel says. "Consequently, a breaker and fuse might be needed ahead of each component, but you also begin to get into a question of economics versus convenience. More breakers can help keep a system running, but most users probably can't afford so many of them. Some users might want a breaker at every I/O point to disconnect power from the field and aid maintenance, but today this can be seen as overkill. It just depends what market you're in, such as packaging machinery or material handling, and how much they need to drive prices down. They'll analyze more closely where they need circuit protection, add fewer where it's used for connection convenience, but keep all their breakers in safety areas."

Jerry Watkins, business team leader for power components at Rockwell Automation (www.rockwellautomation.com), reports that circuit protection has gone beyond shielding individual wires, motors and other parts to protecting all-in-one devices more affordably. "Breakers are gaining more sophisticated electronics, so they can do several functions in one device or enable trip settings, so people can work with them more safely," Watkins says. "Customers also demand higher-rated protection, so we're focusing on testing controls, circuit boards and related devices together as complete systems."

Watkins adds that Rockwell launched its 140G circuit breakers in February, which are intended for global applications and carry multiple certifications from UL, IEC and others. "These breakers can be tested and certified to comply with different standards because the small spacings between their phases are adjustable, which allows them to meet the current ratings and voltage ratings required by the North American and international standards organizations."

Besides benefitting from ECP's intelligence, many newer circuit breakers or other replacement modules are further protected by molded casings and are configured so they can take the places of earlier, consumable counterparts. "We're able to exchange our trip units with core breakers to maintain UL certifications," adds Watkins. 



Device Protection in the Danger Zone

Intrinsic Safety Systems Are Emerging Slowly as an Alternative to Explosion-Proof Solutions in North America. It's Time to Be Clear About How It Works

By Ian Verhappen

Intrinsic safety still is not widely understood in North America. Until recently, explosion-proof practices were commonly used in areas classified as requiring protection.

The need for that protection is based on the likelihood of a potentially flammable atmosphere being present, which, in turn, determines the class in the North American area classification system.

The experience of North American industrial machine builders that sell into hazardous environment markets overwhelmingly has been based on explosion-proof methods.

Instrument manufacturers for industries with these environments, typically hydrocarbon processing-related industries such as refining and chemicals, design their instruments to be both explosion-proof and intrinsically safe (IS). This allows manufacturers to sell the same device anywhere in the world, regardless of the area classification and protection system used by the facility.

Regardless of the method used to prevent fires or explosions in a facility, all methods are designed to remove one of the sides of the "fire triangle" shown in Figure 1.

Explosion-proof and intrinsic safety systems remove (more correctly, manage) or limit the energy level released to the environment. Encapsulation and potting, on the other hand, keep oxygen away from the energy source.

Each gas has its own range of concentrations over which its stoichiometric ratio allows it to burn. Outside this range, combustion, and hence an explosion, will not occur. The extreme example of this: If a device is placed in a 100% methane environment, it will not burn or explode because there is no oxygen present to complete the reaction.

Similarly, every gas has a different temperature at which it ignites. The concept of divisions is based on the type of gas

present, while the "T" or temperature rating is based on gas ignition temperatures.

All these chemical factors must be kept in mind when selecting equipment to be used to prevent explosions.

Prevent or Disperse Explosions?

As indicated, both explosion-proof enclosures and intrinsic safety prevent explosions by limiting the amount of energy in the explosive environment. An explosion-proof enclosure uses its mass and design to disperse the energy to a low level before it escapes the enclosure. Intrinsic safety systems are designed to prevent the energy level in the hazardous area from being above the explosive-limit conditions.

It is important to realize that intrinsic safety is a system. All the components of the system need to be considered in the design, including not only the IS device used to limit the energy available to the hazardous area, but cable and remote devices as well. Passive devices that do not store energy, such as terminal blocks, normally are not an issue and need not be considered. The capacitance of a cable, which is used when calculating the energy stored in a cable, is considerably affected by the presence of a screen or shield. It is important to use the correct capacitance value for the cable type installed.

IS devices, the key components in intrinsic safety systems, are available in two distinct formats: safety barriers and galvanic isolators.

Safety barriers use zener diodes and current-limiting resistors to limit the current and voltage available at the hazardous area terminals. A fuse, if used in the barrier, restricts the fault power; the zeners restrict the voltage; and the resistor restricts the current. Figure 2 is a simplified schematic of a safety barrier. The excess energy from a barrier is routed to ground, normally through a low-impedance bus bar.



Back to Basics

On the other hand, a galvanic isolator (Figure 3), as the name implies, breaks any direct connection between the safe and hazardous area circuits by interposing a layer of insulation between the two areas. The power transfer to the field—important to maintain loop-powered devices—normally is via some form of transformer, while the return signal from the device in the hazardous area is transmitted across the hazardous area/safe boundary via an optocoupler, transformer or relay.

The final power limitation to the hazardous area is accomplished with a diode and resistor network similar to that of the safety barrier. Because galvanic isolators have different methods of forwarding the return signal to the safe area, they must be matched to the application.

Because a galvanic isolator removes any direct connection between the hazardous and safe areas, safety barriers require a good path to ground. That makes the factory ground system the predominant potential source for signal noise, with the result that proper grounding or earthing techniques must be followed. The two main reasons for grounding instrument systems are to minimize interference while providing a signal reference, and to segregate and define the fault path requirements for safe dispersion of excess energy. Rapid energy dissipation is required to prevent a fire or explosion.

The standard industry practice of grounding instrument circuits at only one point is critical to the success of intrinsically safe circuits. In addition, the IS circuits should be isolated to withstand a 500 V insulation test. However, the use of galvanic isolators as an interface reduces the criticality of a well-designed and functioning ground grid with minimal potentials across the plant. Therefore, if some remote apparatus requires a separate power supply—i.e., they are not loop-powered, four-wire devices—then the preferred solution to maintain an IS circuit is galvanic isolators at either end of the cable.

It is worth noting the isolators form the boundaries between the two safe areas and the single hazardous area. The safe area at the control system end often is a rack room or unclassified area, while the safe area at the remote device end may have to be created through the use of either explosion-proof or purged housings.

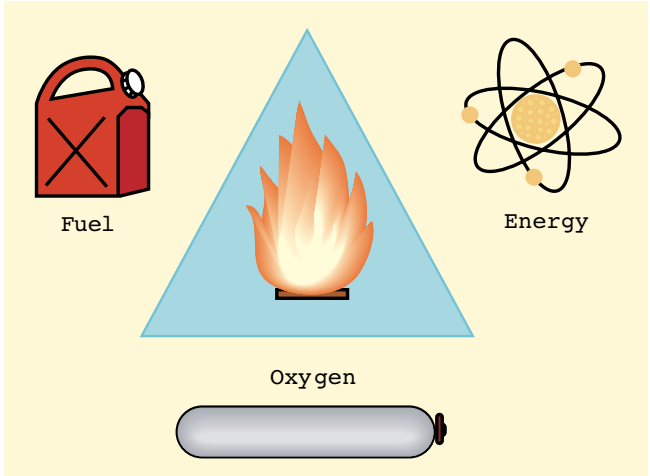

BREAK UP THE TEAM

Figure 1: At least one side of the well-known ‘fire triangle’ must be removed to prevent fires or explosions.

Most industrial instrumentation cables include a ground wire as part of the wires within the overall insulated product. Many cables also include a screen or shield to limit the effects of nearby cables. It is especially important to use individually shielded conductors for any type of fieldbus installation.

Screens or shields normally are terminated in junction boxes without bonding them to the structure. The shields then are connected through the terminal to the home-run cable and the host system and its associated ground point. For the same reason, unused conductors in a cable should be terminated in a terminal so that, if used in the future, they already are connected, and to ensure they are not an inadvertent source of a spark, short circuit or ground loop.

When screens/shields are used to guard against pickup of high frequencies, they usually are earthed at a number of points to prevent the screen from presenting a tuned aerial to the high frequency. For IS circuits with this problem, the acceptable solution is to include 1,000 pF capacitors to ground at convenient points such as junction boxes. This effectively detunes the screen, but does not provide a path for the low-frequency currents, which can cause interference problems to flow off the screen or shield.

Back to Basics

Ground the Buses

Most new installations and many existing transmitters use smart devices capable of some form of digital communication. This can be as simple as the HART protocol that is superimposed on the 4–20 mA signal, or a full fieldbus solution such as Foundation fieldbus or Profibus. Any circuit that has a fieldbus signal must use galvanic isolation. This is because the grounding required by safety barriers will route the signal itself to ground as well. Those isolators have to be designed to operate at the specific frequency transmitted. That follows from the discussion above about each isolator type being matched to its service and the frequency “tuning.”

The ISA-50, IEC 61158 standard-based fieldbuses also must adhere to the energy limitations as dictated above. That is why intrinsically safe Foundation fieldbus networks normally are restricted to approximately four devices per network. Since the original justification, at least to project managers and others focused on the upfront or construction costs of a project, invariably included easily identified ways to at least break even, the reduction in wiring was an obvious target. Fieldbus devices typically consume about 20 mA. So if a segment can support 80 mA, the result is that IS circuits significantly reduce the benefits of networking by reducing the number of devices on a network from 8–12 devices down to 4–6 devices.

True to form, industrial connector suppliers found several innovative ways around this problem. The most common, and the one incorporated into existing standards, is the Fieldbus Intrinsically Safe Concept (FISCO), based on work by Physikalisch-Technischen Bundesanstalt (www.ptb.de). It demonstrates that if the inductance and capacitance per unit length of field cables are within defined limits, then the risk of spark ignition does not increase with total length. The safe operating levels of the power supplies with electronic current limiting also were established, which allowed the use of higher currents on the network, typically 130 mA.

The result is that 6–8 devices now can be installed on a FISCO network. Other benefits of FISCO systems:

- The system can be created by any combination of apparatus that are certified as FISCO apparatus.

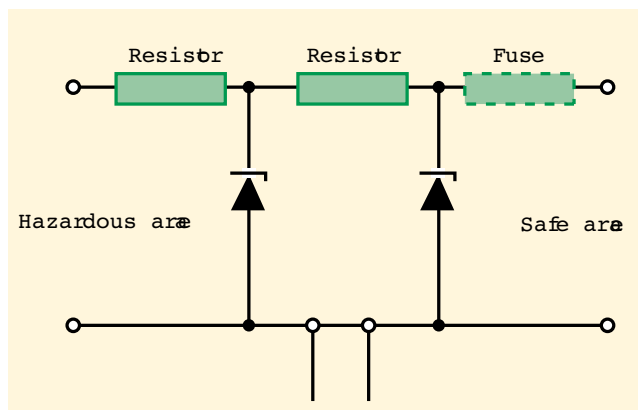

SIMPLIFIED SAFETY BARRIER

Figure 2: In this simplified schematic of a safety barrier, resistors limit the current, and zener diodes restrict voltage available at terminals in the hazardous area.

- No analysis of the input capacitance and input inductance parameters is necessary.
- The documentation requirement is reduced to a list of apparatus used.

The key is the devices must be FISCO-approved and, at present, there are few of those, although many manufacturers now are obtaining this certification.

A number of manufacturers also are making field-based barriers. These allow running a higher current level to the field on the home-run cables to an active field-mounted box. This box contains the circuitry to reduce the energy on each individual spur from the field barrier/junction box connecting the device to the balance of the network.

Another more recent innovation that is proceeding toward a vote by the IEC 60079-27 committee is the Fieldbus Non-incendive Concept (FNICO). FNICO is applicable only in Zone 2 (Div. 2) areas, and takes advantage of the fact that since the potential for a hazard to exist is reduced by being present only in abnormal circumstances, the use of Type ‘n’ protection can be applied.

Because FNICO requires only a safety factor of 1.1, vs. the 1.5 safety factor for IS and FISCO systems, it can provide more energy to the network, typically 180 mA. Figure 4 shows the power supply design limits for various area classifications.

Back to Basics

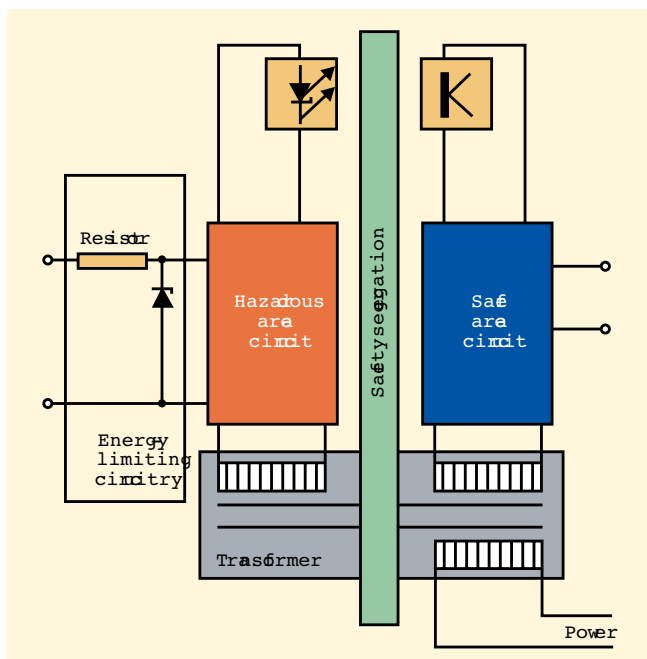

POSITIVELY GALVANIC

Figure 3: Galvanic isolators break any direct connection between the safe and hazardous area circuits by interposing a layer of insulation between the two areas.

This additional energy works out to allow a FNICO system to more than double the number of devices on an IS network, yet it provides the same flexibility to work on a live system.

FNICO networks also have the benefits of FISCO, relative to documentation and calculation requirements, while not requiring any special certification beyond the IS approvals already required by most instruments.

IEC standards suggest that live working is permitted in Zone 2 installations if it can be demonstrated that an incendive spark or hot spot cannot be caused by the activity. This implies that working on a live instrument or circuit is possible with a gas clearance/hot work permit.

Instrument circuits, however, run the risk that a fault injected at one point might create a hazard at another interconnected piece of equipment. For example, in a temperature-sensing loop, a signal injected at the thermocouple

IS UPDATE 2013

There have been a number of changes in the intrinsic safety (IS) arena since this article was published in 2005, and most of those changes are involved with IEC 61158 networks and IS equivalent offerings.

The most significant change to the IEC 60079-11 standards is replacement of the FNICO standard with the FISCO ic rating. FNICO installations are “grandfathered” and the new rating is effectively equivalent, but is incorporated in a single document.

One of the “knocks” against FISCO was that it wasn’t possible to purchase redundant power supplies, which could result in a single point of failure and hence restricted its adoption. With advances in electronics that enable rapid switching of circuits within the time period of a single message packet, MTL developed and released a Redundant FISCO product.

Also relying on fast circuitry, Pepperl+Fuchs and PTB developed dynamic arc recognition and termination (DART) as an IS equivalent circuit able to provide benefits of IS without the energy restrictions with which it is commonly associated.

Another technology that supports the IS Entity concept while allowing higher levels of energy in the complete system is the MooreHawke RouteMaster split architecture model that effectively splits the resistive network managing the energy levels in the system between both ends of the cable.

—Ian Verhappen

head could manifest as an unsafe energy level at the transmitter, local indicator or computer interface. So the gas test associated with the hot work permit is required at all three locations.

The majority of new installations are at least considering the use of digital communications protocols in the design. Despite being around for almost 10 years, fieldbus systems still are relatively new, and manufacturers continue to develop innovative ways to provide the maximum flexibility and return on a facility investment. 



Technology in Action

Flexibility Is Key to Automated Welding

Change in I/O and Control Architecture Supports Drive for Versatile, Flexible Welding Machinery

by Larry Koscielski, CenterLine Limited

The one sure thing that a machine builder faces is the knowledge that today's machines won't be good enough tomorrow. The face of manufacturing changed from a long-run, infrequent-changeover, inflexible production scheme to one that demands machines that can produce high-quality products safely with the versatility and ease of use required to change over and make other products quickly and accurately.

The machine builder that doesn't think about its future machine designs in that fashion might not be around long enough to have a next-generation machine.

CenterLine Limited (www.cntrline.com) in Windsor, Ontario, is determined to be around for a long time. We are a Canadian-based, privately held company that specializes in advanced automation processes and technologies that satisfy resistance-welding, metal-forming and cold-spray application needs.

The company is vertically integrated with products ranging from consumables to fully automated production systems. Main customers include original equipment manufacturers and tier suppliers in automotive, mass transit, aerospace and defense.

CenterLine is established internationally with manufacturing and service support facilities currently located in the United States, Mexico, Brazil, Germany, Romania, India and China. These operations help support CenterLine's customer operations internationally.

Challenging Customer Demands

In the process of updating our popular FlexFast welding machines (Figure 1), our company identified several requirements for increased flexibility and performance. Because the FlexFast's unique modular design is used

for applications ranging from advanced fastener (nut & stud) welding to other resistance-welding applications, the versatility of the equipment needed to be supported by a controls architecture that was just as flexible.

In operation, a programmable servo axis moves the fixture that holds the part or parts in place to an operating area where a similarly programmed motion profile places the parts (nuts, studs) to be welded in position, and moves the welding electrodes in place to execute the welds based on the programmed "recipe" in the controlling PLC.

The design update was required to satisfy an expanding, globally competitive market, and to meet the demands of a growing customer base. To extend the flexibility of the machine, CenterLine needed an I/O and controls design that provided a common platform, allowed for a growing variety of tooling, and enabled its machines to interface with many different controller brands regardless of customer specifications. "We were looking for a globally available platform that would be fast, flexible and provide the features that would satisfy the needs of our international customers," says Simon Britton, controls technologist at CenterLine. "When we evaluated various solutions, we decided to move away from DeviceNet and considered an Ethernet/IO-Link solution.

Controls manager Scott Pittl says that DeviceNet didn't give the Flexfast the update speeds it needed. "There's a lot of analog information, such as VeriFast electrode information that measures the position of the welding pin and the position of the upper electrode, passing through the network from devices," he explains. "All of this is needed quickly and precisely to make a 'weld proceed' and 'weld complete' decision."

Technology in Action

Unique ID Manages Fixtures

A main hurdle with Ethernet was how to handle the analog signals effectively. IO-Link (www.io-link.com) was a solution that had the proper signal resolution we were seeking, as well as being very competitively priced and accepted internationally. That particular value proposition made it easy for us to select IO-Link.

The new FlexFast design also demanded a controls architecture that could easily integrate new automation components with minimal concern. “The need to integrate new components on the machine quickly and easily is critical to addressing ongoing changes in production needs that this equipment is expected to satisfy,” Britton adds. “For example, one challenge was that standard mechanical components and custom controls affect how the tooling fixture that holds the part is configured (Figure 2). IO-Link allowed us to standardize many tooling fixture elements and run manufacturing in batches, which resulted in improving the modularity of the overall platform at an improved cost and faster turnaround time.”

IO-Link gives us the possibility to assign a unique engineering ID number to each fixture. With IO-Link, we can call it that number, and even with multiples of the same fixture, we can identify them individually with a memory-accessed node address on the fixture. We couldn't do that with DeviceNet.

To realize these objectives, CenterLine partnered with Balluff (www.balluff.com), a global sensor, networking and RFID component supplier. This enabled CenterLine to use a distributed modular I/O solution that incorporates IO-Link technology. IO-Link is a universal, vendor-neutral standard designed to make it easy to integrate automation components into any control architecture.

There's a high level of acceptance of Balluff in our industry and Balluff has been very proactive in supporting our needs, so it was the logical IO-Link supplier for us.



CENTERLINE

UPDATE TO A MORE RESPONSIVE PLATFORM

Figure 1: A standards-based, industry-accepted communication solution of EtherNet/IP and IO-Link provided the flexibility, speed, information handling and ease of use for CenterLine's updated FlexFast welding machines.

By specifying Balluff's I/O hubs with built-in identification data, CenterLine was able to operate multiple tooling fixtures with the same standard machine.

Technology in Action

“This was possible with our old DeviceNet solution, but it only could be effectively applied on one machine at a time; in other words, one machine, several tooling plate fixtures, since the available identification format wasn’t large or versatile enough to allow us to track individual tooling from design all the way through the equipment build,” Pittl explains. “Essentially, we now can identify every single tooling plate uniquely without duplication, and that information can be written to the tooling block control to identify every single tool on a project accurately, regardless of machine. This makes it possible for us to move tooling across different machines. Since the ID is generated in engineering during design, it’s maintained all through our other business systems, so we can accurately track it all the way through a project and into the installation environment. It’s as if the tooling has a fingerprint.”

This increased the flexibility and intelligence of the equipment without increasing the overall cost of the machine. Moreover, it enabled CenterLine to accurately track interchangeable tools to ensure proper machine setup.

Essentially, IO-Link allowed CenterLine to have a common control architecture while easily integrating a wide variety of sensing and control components. “IO-Link supports the versatility of our product line, and the new design streamlines the design of the equipment while reducing cycle time and increasing machine throughput,” CenterLine product engineer Adam Waites says.

A Significant Improvement

“It’s important to mention that the improvements in configuring the systems have been significant,” Waites adds. “In the past, an average machine could take up to a day to configure. With IO-Link, we tend to do it in about two hours. On large programs this is a very visible savings, and also helps us maintain consistent practices.”

Of particular importance is that IO-Link talks to any



SET UP, STANDARDIZE AND CONFIGURE FASTER

Figure 2: With IO-Link, CenterLine can identify each welding fixture with a unique number and, even with multiples of the same fixture, can identify them individually with a memory-accessed node address on the fixture.

fieldbus. “Whether our customer uses EtherNet/IP, DeviceNet, Profibus or Profinet, we don’t have to worry about platform standards,” Britton adds. “Whatever they require, we’ve been able to accommodate using various masters that Balluff provided that connect to each of these protocols and drop down to IO-Link.”

Gateway to Ethernet

IO-Link operates in a similar manner to a gateway for most fieldbus protocols,” adds Will Healy, networking marketing manager for Balluff. “Or a simpler realization is a master/slave relationship. The IO-Link master is a slave on the Ethernet I/O network, and acts as a master to the individual IO-Link slave devices. The data from the devices appears on the fieldbus as a maximum of 32 bytes input and 32 bytes output.



Technology in Action

Thus the data is easily realized to the controller and then can be communicated via the controller to the ERP or CMM systems. Add-on instructions (AOIs) or function blocks are used by the engineering software to integrate the bitmap into usable, data-like switch points, measurements or diagnostics.”

By integrating IO-Link components into its machine, CenterLine was able to fulfill its need for increased flexibility and improved cycle time. “We saved up to a second per weld by making these changes, with half of that saving coming directly from IO-Link integration and half from mechanical improvements we made to the equipment and our change to Ethernet,” says CenterLine’s Pittl. “By facilitating and improving the processing of the analog signals at the weld point, we realized up to one second per weld cycle time improvement all at a reduced implementation cost.”

Remote Is Better

Could this machine be connected with a centralized I/O system rather than distributed via the I/O blocks? Yes, a centralized I/O system could have been used in this application, but we think that comes with a set of problems. Centralized I/O requires greater wiring efforts, has fewer diagnostics, less intelligence and ultimately might be a greater risk for us and our customers.

“The benefit of a modular decentralized solution is seen in a setup like CenterLine’s,” Balluff’s Healy states. “With multiple tool changes, a centralized I/O system can be a struggle to wire and configure on tool changes. With a centralized I/O system, large multi-conductor connectors are used, and these require regular maintenance or replacement. And, if someone forgets to disconnect it before removing a tool, a significant amount of downtime can occur for repair of the tool and machine.”

The Road Ahead

Now that CenterLine has integrated IO-Link into its machines, our future designs can quickly and easily take

advantage of the value of other IO-Link technologies such as the Smart Light stack light and valve manifold control. The company also uses the remote IO-Link solution on some of its other automated systems, and has realized similar benefits.

New Kid on the Block

IO-Link is relatively new to North America, compared with Europe, for example, and we sometimes see some resistance to its use, but when we demonstrate the benefits, we have been able to sell it. The biggest hurdle was that customers did not have spare I/O blocks, so we included spares in many of our proposals. Our company believes that IO-Link is ready to handle expanding requirements for years to come.

“IO-Link does not replace a digital fieldbus. In fact, IO-Link can be thought of as enhancing existing fieldbus and Ethernet technologies,” says Jason Dias, head of quality and technical support for Balluff Canada. “IO-Link makes use of the current controls architecture, and delivers more functionality, diagnostics and intelligence—all in a more cost-effective and easy to implement package.”

What our company offers today could be very different from what we offer in the future. IO-Link being an open standard allows for new devices to be implemented at the customer’s request.

At some point, CenterLine will start to make better use of the remote diagnostics and troubleshooting capabilities for its installed machines. IO-Link devices provide a diverse selection of diagnostic data from operational status to maintenance required. In addition, the IO-Link master stores all of the configuration data of slave devices, and can reprogram a replacement to a broken part automatically. This means a basic maintenance technician can replace a complex device as easy as a prox switch without a manual or instruction. This reduces the number of service calls to the machine builder. ☐

Waterjet Cutting Systems for the Toughest Tasks

Ultra-High Pressure System with Five-Axis, PC-Based

Motion Control System Reduces Operating Costs with Zero Controller Failures

by Nancy Lauseng, Jet Edge

Waterjets are among the most flexible cutting systems available. They can cut virtually any material and have become a principal method of fabrication and metalworking for a variety of compelling reasons.

Jet Edge (<http://jetedge.com>) in St. Michael, Minnesota, is a leading developer of this technology, designing and manufacturing ultra-high pressure waterjet systems for precision and mobile cutting, water blasting and surface preparation. Jet Edge offers an extensive range of systems that gives customers flexibility in choosing a solution that best meets their needs.

As a high-profile example, during the Gulf of Mexico oil spill in 2010, British Petroleum needed a waterjet system that was operable 5,000 feet under water. To deal with a major, time-critical problem that had never been solved before, Jet Edge created a system that blasted away hydrate ice crystals clogging a containment system and preventing BP from stopping the flow of crude oil into the Gulf.

Of course, most Jet Edge machines are on the shop floor, not the sea floor. Ultra-high pressure (UHP) pumps and waterjet cutting machines enable fabricators cut intricate parts in all types of materials ranging from soft foams and rubber gasket stock to thick tool steels and space-age composites. The cuts can be simple straight lines or can be extremely intricate, with large or small pierced holes. By using waterjet cutting systems (a cold-cutting process), fabricators avoid heat-affected zones (HAZ) and don't burn the material during cutting. They can enjoy reduced raw material waste and less damage from cutting that would otherwise require rework or secondary processing. Waterjet cutting systems also can be used in applications that process flammable materials. More traditional ways of cutting parts include stamping with metal dies, shearing and sawing

(dies, knives and blades dull over time), laser cutters (limited to cutting thinner metals and can't be used to cut highly reflective materials) and plasma cutters (limited to cutting metals and can't cut materials as thick as a waterjet can cut).

Waterjet systems have a higher initial acquisition cost than saws, plasma cutters and flame/torch cutting systems, and they cut slower than saws, plasma, lasers or torch systems and stamping systems. Waterjets, however, are an excellent choice for shops that require the versatility to cut a wide range of materials, including thick materials and those that need to eliminate HAZ.

Complex Cutting With PC-Based Control

"To maintain extraordinary levels of precision, high-end motion control is critical, especially for maintaining cut edge quality and for meeting tight dimensional tolerances," says Jude Lague, Jet Edge's president. "Accuracies of cuts often must be within 0.005 inch or less. Waterjet manufacturers such as Jet Edge meet these requirements by powering their equipment with fast, accurate, reliable and consistent motion control products and sophisticated software. Our gantries feature a closed-loop drive system on X and Y axes; ac digital brushless servomotors, absolute encoders and SERCOS communications. They include preloaded anti-backlash recirculating ball screws and linear bearings with hardened precision ground ways."

The need for a flexible system is also important, Lague states. "We needed an open system that could easily integrate the full array of sensors that Jet Edge uses, while providing intricate motion control."

Jet Edge motion controls started with traditional industrial

Technology in Action

PC-based analog controls supplied by major vendors and more specialized custom manufacturers.

Ten years ago, Jet Edge decided to change to a digital motion control platform. “With the progression of our technology and our previous controls vendor not advancing its code, we needed a new platform that could help our technology grow,” Lague says. “After an extensive search, we chose to work with Beckhoff Automation (www.beckhoff.com) for a complete control solution. With Beckhoff industrial PCs (IPCs) and TwinCAT CNC software, Jet Edge was able to seamlessly and incrementally migrate to new technology. We chose Beckhoff for its flexibility and because the company is conveniently located here in Minnesota.”

The TwinCAT system has become an integral component in Jet Edge’s high-rail and mid-rail gantry machines. Jet Edge partnered with the Beckhoff to rewrite the Jet Edge HMI, and created an innovative CNC waterjet motion system by harnessing the power of the CNC capabilities in TwinCAT. The high-rail and mid-rail gantry systems are designed to be exceptionally stable with a rigid platform that minimizes machine vibration. The system is capable of advanced three-dimensional waterjet movement over the work area and ultra-high precision cutting.

Since making the shift to TwinCAT software, Jet Edge has seen an overall improvement in cutting tolerance and cut edge quality. “This is difficult to define as a numeric value, but we can operate with higher machine resolution with the new control system,” says Jeff Schibley, Jet Edge regional manager. “This is partially associated with the speed and response time of the system in conjunction with SERCOS and a higher resolution motor and drive package. The cutting system now is less forgiving of programming errors. In the Aquavision 1, the operator could execute a program with sloppy geometry and overlapping kerfs in the cutting path. The new control gives the operators an error code and tells them they should not do that because they are going to produce an inaccurate part.”

Running TwinCAT CNC software on IPCs enables Jet Edge to implement complete machine control and HMI with tightly coupled PLC functionality and multi-axis motion control processes. “TwinCAT and the IPCs work together on positioning tolerance, speeds and positioning,” Schibley explains. “The IPC

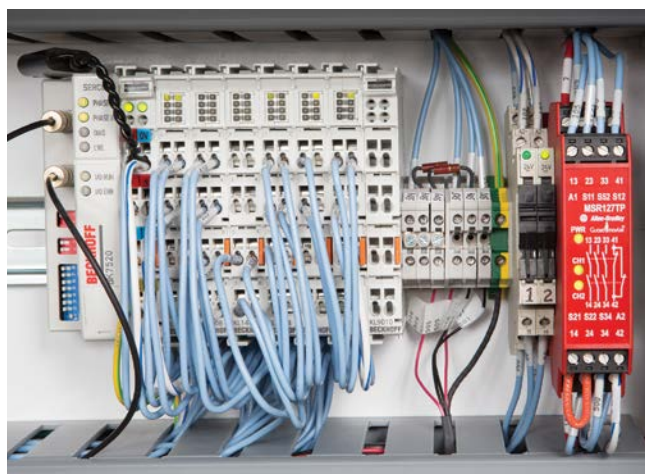

JET EDGE

TAKING THE BUS

Figure 1: Bus couplers connect the SERCOS bus system to the I/O terminals and provide the connection back to the central IPC.

controls on/off functions of valves, block retrace, height sensors, laser mapping, servo communications and a portion of everything the cutting table does. The IPC can control the peripheral equipment without affecting the data execution of TwinCAT controlling the program path.”

For the machine display, Jet Edge uses “economy” control panels with DVI/USB extension technology, which permits installation up to 50 meters away from the IPC. The 15-in. display has an aluminum front with sheet-steel rear cover, front-side IP65-rated and rear side, IP20.

The system integrates with SERCOS II. The IPC-specified features include a SERCOS mini-PCI fieldbus card that connects via fiber-optic cables for the SERCOS networking used in the machine for I/O and drive networking. The compact IPC is designed for control cabinet installation and all connections, including fieldbus and standard PC interfaces, are conveniently located at the front of the IPC housing. Cooling is managed by internal cooling fins and an exchangeable fan cartridge at the bottom of the IPC housing.

“Bus terminal I/O is used to implement a variety of Jet Edge machine functions,” Lague adds. “Analog bus terminals assist with height sensors and plate mapping, while digital I/O terminals are leveraged for control relays and solenoid valves.

Technology in Action

Bus couplers (Figure 1) connect the SERCOS bus system to the I/O terminals and provide the connection back to the central IPC.”

With regard to integrated safety, Schibley says the light curtains, safety mats, shuttle tables, conveyors and peripheral equipment are controlled by the IPC, which communicates the status of these to the Beckhoff system, adding that Jet Edge doesn’t have to purchase a separate stand-alone PLC to control the peripherals.

Gives Us the Edge

The new technology resulted in the design and build of Edge X-5 (Figure 2), a five-axis waterjet system that cuts complex, taper-free and 3D parts from virtually any material (Figure 3, page 36). It features a Beckhoff IPC controller running CNC software programmed specifically for 5-axis waterjet cutting. The Jet Edge AquaVision Di controller offers an open architecture design that enables users to choose from many CAD/CAM/nesting software providers or to use standard G & M code.

The controller operates on Microsoft Windows 7, and it’s customary for Jet Edge to supply nesting and cut optimization software by Swedish company IGEMS (www.igems.se). This software also produces the post processor file.

“While it’s usually not the case, we don’t always supply the operating software,” Lague says. “However, it demonstrates the flexibility in the Jet Edge platform, so it does happen. Many or most of the large waterjet manufacturers will design and assemble their own proprietary hardware platforms and use their own CNC and cutting path trajectory software, as well as their own HMI software. This can limit the flexibility of their systems by restricting the customer’s software selection. For example, if a Jet Edge customer wants to cut advanced aerospace components using proprietary software and cutting techniques, that customer often can integrate its software to the AquaVision Di control’s operations without modifying the manufacturer’s proprietary software. Our system’s Intelligent Work Envelope automatically adjusts cutting processes depending on the angle of the cut to protect the operator, material and system components. Using this feature-rich solution, the machine operator can adjust the cutting parameters with ease. Even for the more technically



JET EDGE

THE CUTTING EDGE

Figure 2: Jet Edge’s Edge X-5 is a five-axis waterjet system that cuts complex, taper-free and 3D parts from virtually any material. It features an IPC controller running CNC software programmed specifically for five-axis waterjet cutting.

advanced CNC users, engineers can still ‘get into the software’ and modify parameters to their specifications.”

Michael Waltrip Racing Selects Jet Edge

To create high-performance mechanical parts, Michael Waltrip Racing (MWR) selected the Edge X-5 to complement an existing three-axis system from Jet Edge. MWR uses its waterjet machinery to cut more than 1,000 parts for each of its NASCAR Sprint Cup cars. The team assembles about 56 cars per year, including the #55 Aaron’s Dream Machine Toyota Camry and the #15 5-Hour Energy/Peak Toyota Camry driven by Clint Bowyer.

“To win high-profile business such as this, Jet Edge delivers high-pressure water solutions that operate at 36,000 psi to 90,000 psi with direct-drive electric or diesel-powered pumps ranging in size from 30 to 280 hp that can successfully run at 55,000 psi and produce UHP flow rates from 0.6 to 7.2 gpm to UHP cutting heads with advanced motion control systems,” Lague explains. “These cutting heads can cut three-dimensional patterns in most materials when placed on a flat surface. The heads are connected to an overhead gantry system that moves over the cutting surface to make intricate and flawless parts.” The powerful cutting force of

Technology in Action

the waterjet stream is kept under control using a 36-in. deep water tank that harmlessly dissipates the cutting stream and prevents it from cutting through the factory floor.

Waterjet cut parts can range in size from that of a gear in a Swiss wristwatch to 100 feet long or more. However, parts are most often cut from plates or sheets that are 4 x 8, 6 x 10, or 6 x 12 ft in size. Waterjet cutting envelopes most often are designed to capitalize on these sheet sizes, although larger Jet Edge systems that accommodate 20 x 12-ft sheets are not uncommon.

Further pushing the limits of waterjet cutting, Jet Edge established its 90,000-psi X-Stream pressure pump technology, which enables customers to cut parts faster and reduce operating costs by using less abrasive material, water and electricity. “X-Stream pressure pump technology led to the development of a revolutionary metal-on-metal seal technology that eliminates 50% of the required seals on our pumps,” Schibley says. “This is hugely important in terms of service and maintenance, considering that conventional seals eventually need to be replaced.”

Bus Transfer

“The control system in our waterjet machines is no longer a limiting factor for volume, speed, accuracy or quality. Jet Edge is much farther down the road in reducing our production costs than we would have been with PLC controls,” Schibley says.

In the initial selection of a new motion control platform 10 years ago, Jet Edge avoided any solution that didn’t have an open architecture, Schibley notes. “We would not accept buying an endless array of control-related equipment from the most expensive vendors out there,” he adds. “This was another principal reason why Jet Edge chose Beckhoff Automation. Jet Edge replaced its controls and still retained the motor/drive components that formed a large part of its product platform. Some suppliers require that when you buy their control, you also must buy their motors and drives. Beckhoff didn’t do that.”

The analog controls previously used by Jet Edge in the 1990s generally had five-to-10 year operating lives, limited by computer component availability, operating software code changes and technical obsolescence. “The control products are extremely durable,” Lague explains. “We have eliminated



SUPER CUTS

Figure 3: The CNC waterjet motion system is capable of advanced three-dimensional waterjet movement over the work area and ultra-high precision cutting.

the warranty expenses and controller failures characterized by non-industrial PC platforms of the 1990s. In 10 years of operating Beckhoff controls in harsh waterjet cutting environments, Jet Edge never has had to replace a controller.”

Next-Gen?

In continuing the company’s evolution of automation and controls, Jet Edge is evaluating a change from SERCOS to EtherCAT industrial Ethernet for its motion and I/O bus. We think EtherCAT will help Jet Edge to extend its limits of machine performance into the foreseeable future.

What are the likely new short-term requirements our customers will ask for moving forward? How will the next-gen machine automation scheme be changing? “We know that customers need to cut volumetric shapes in 3D space,” Lague notes. “When other waterjet manufacturers build that type of machine, I believe they switch to a higher-priced and higher-featured control rather than their proprietary control. Jet Edge will be able to simply integrate the 3D software into the existing AquaVision Di. We already use the higher-featured control system.” 

Technology in Action

Flexible Conveyors? Look Up

OCS IntelliTrak's Modular Overhead Conveyors Help Keep Up With Rapid Design Changes.

by Jim Montague, Executive Editor

Mass production used to mean everyone got the same product. Well, those days are long gone. To accomplish today's goals of producing numerous, customized products faster, automotive and subassembly manufacturers need extreme levels of flexibility in their production lines, and IntelliTrak's overhead conveyor systems give it to them.

Located in Fairfield, Ohio, OCS IntelliTrak (www.intellittrak.com) builds modular, overhead conveyor systems that are used for manufacturing and assembling numerous parts, including front-end modules, door lines, engine lines, instrument panels, seats, headliners and center consoles.

Using technology licensed from OCS in Borås, Sweden, IntelliTrak was founded in 1995, and still produces the only rotating-tube, friction-drive conveyors in North America. Driven by skewed wheels, trolleys ride on IntelliTrak's load rail, while the drive beam's spinning tube is attached via bearing assemblies. Operators can change trolley direction easily by reversing the drive tube's rotation. This rotating tube also requires no lubrication for cleaner, quieter operation.

The flexibility of the company's overhead conveyors, such as its IntelliTrak 500 Series, come from their bolt-together design. This enables easy system changes for new car designs, allows manufacturing zones to be added or removed from the line with minimal impact, eliminates the need for many replacement systems, and reduces downtime and costs.

"Because our customers' needs change so quickly now, 50 to 70% of our systems will be modified within the first five years of implementation," says Tom Robertson, IntelliTrak's president. "Fortunately, we can unbolt the end of our overhead conveyors, and add two, four or eight more stations in just a few hours. This job usually takes two weeks with traditional conveyors. In fact, we recently added a 10-foot inspection station with camera to check airbag switches on the Dodge Dakota instrument panel line at Chrysler's plant in Warren, Michigan, and we were able to get it up and running in just four hours on a Saturday."



DASHBOARDS DASH

This automotive assembly line uses the IntelliTrak 500 overhead conveyor system to build instrument panels, while its modular components can be reconfigured quickly for new designs.

The modularity of IntelliTrak's conveyors is further aided by its controls, which include drives and I/O distributed throughout each separately driven zone. These controls include programmable automation controllers (PACs), distributed motor controllers and I/O modules from Rockwell Automation (www.rockwellautomation.com), which are networked via EtherNet/IP. Distributed motor controls enable each carrier and zone to run independently and at varying speeds, which allows production line speeds to be matched to different assembly tasks, prevents parts from being tied up on the line, increases efficiency and saves time.

"One of our primary benefits is that we can independently control all zones in a user's process and stop, slow, reverse and move carriers back and forth, and even create movement recipes that best suit the geometry needed for each part," explains Robertson. "This means we can clean, paint or assemble many parts much more efficiently. Our distributed drives and remote I/O also mean we don't have to send hundreds of wires back to a main enclosure." 

Control the Roll

Wynright Embraces Ethernet, Control to Make Smarter Conveyors.

by Aaron Hand, Managing Editor

Through its 40-year history, not only has Wynright changed its name and corporate structure, it's changed its whole outlook on controls and networking. Because of that change in perspective, consolidation and growth is fueling the staffing of experienced software and controls engineers, which enables Wynright to provide more intelligent material handling solutions.

Wynright (www.wynright.com), headquartered in Elk Grove Village, Ill., was founded in 1972 as WEi. Its Automotion brand conveyor and sortation systems were launched in 1973. Like most conveyor suppliers, Wynright's traditional systems are driven by a belt that makes the rollers turn. The company also makes traditional live roller and gravity conveyors.

But the company really changed its direction beginning in early 2009, when Wynright's chairman Mike Scheck consolidated several different but related material handling companies under the new Wynright name. "That was when we really made our commitment to controls, software and support," says John Dillon, president of Wynright's Control Solutions division in Oak Lawn, Ill. That was also when Wynright formed the control group. "As opposed to it being fragmented or partially outsourced, we really tied it all together and focused on our investment in that area."

Out of that commitment grew a completely different kind of conveyor system in its AutoRoll+, a motor-driven roller (MDR) conveyor released about two years ago. Run-on-demand zones reduce energy consumption and overall noise, and extend the functional life of the conveyor. It also uses Ethernet connectivity, which offers simplified installation, greater flexibility with respect to conveyor controls, enhanced diagnostics, and remote visibility of the overall system.

Since January 2009, Wynright has grown to more than 30 controls engineers, and has done the same with its software



WYNRIGHT

CONVEY EFFICIENCY

AutoRoll+ conveyors operate in 5 ft zones that sleep when not in use.

engineers. "AutoRoll+ is part of that," Dillon says. "You take equipment that was less intelligent and now it's more intelligent, so you need controls expertise for that."

Rather than having a 200 ft section driven by a large, noisy 480 V motor, AutoRoll+ divides the conveyor system into a series of 5 ft zones, each driven by a 24 V motor embedded in a roller. "There are a lot more motors, but they're more efficient," Dillon says, noting that traditional conveyor motors require much more torque to start and stop. In the new conveyor system, every zone goes to sleep until needed. "When that happens, you're saving power."

Ethernet also plays a large part in Wynright's technical advances over the past few years. Each zone in the AutoRoll+ includes an Ethernet card with its own IP address, enabling the zones to communicate with each other. The standard mode of the card can handle 95% of the applications, Dillon says. "The firmware is embedded in each card, and tells the cards how to

Technology in Action

communicate with each other,” he explains. Each zone in a conveyor communicates with the other zones, sensing and reporting line-full conditions, jams, and other necessary data to ensure the product navigates the system safely and efficiently. “In specialized situations, such as with a robotic pick-and-place system, we can disable the firmware and control those specific cards strictly through the PLC.”

The firmware—which is specified by Wynright—has improved over time so that acceleration and deceleration profiles enable higher speeds and increased flexibility. If a customer’s product mix changes, Wynright can easily go into the IP and make adjustments. “We had a situation where, late in the installation process, our client asked if the system could handle some top-heavy cartons, well outside the parameters for which the system was designed. We were able to go in through the EtherNet/IP and fine-tune the acceleration/deceleration profile, making it possible to handle the cartons without tipping over,” Dillon says. “In the past, you’d have to make adjustments to each and every card.”

Wynright is completely sold on the advantages of EtherNet/IP, according to Dillon. “We’ve moved more and more to EtherNet/IP across all of our control systems, just in terms of the size of the pipe and the volume it can handle,” he says. “It’s an exciting time because even Rockwell’s rolling out Ethernet on just about everything this year.”

Late last year, Wynright was awarded membership into the Rockwell Automation Machine Builder Program, giving it closer communication with Rockwell about the direction that each partner is heading with its technology. “We’ll collaborate with them as we design our new EtherNet/IP solutions,” Dillon explains. “We also bring them in on larger projects to help us with the architecture of the system.”

Although obviously Wynright uses its share of Rockwell parts, the conveyor manufacturer does not let that limit its outlook on control architectures. “Some people prefer strictly PLC and others prefer strictly PC. We’re big believers that there’s a place for both,” Dillon says. “Even as a Rockwell company partner—and I’ve told them this—the PLC is great for machine control. Where the PC has its advantages is at the supervisory level.”

Wynright offers support options to its customers in which the supervisory component has been a key benefit. Support calls



TALK THE TALK

Each zone on the AutoRoll+ includes its own Ethernet card and IP address to communicate with other zones along the conveyor system.

now can be done through a VPN connection, going through the IP addresses to look at a specific card’s registries to see whether a roller’s healthy, Dillon explains. “For example, if a roller that averages 1.2 A is running at 1.7 A, the tracking capabilities of the software help a maintenance person with diagnosis,” he says. “In the event a zone won’t run, we can get in there and say, ‘Replace the roller’ or ‘Replace the card’ vs. ‘Well, try this, try that.’”

The next step is to get that data out into real-time reporting to provide daily reports for maintenance, Dillon adds. “We can proactively say, ‘Hey, these rollers have run 7,000 hours and are starting to show signs of increased amperage draw.’ It’s the difference between struggling through unforeseen downtime and planning for non-evasive scheduled maintenance.”

Customers in the retail distribution space have reached a point where they are more than willing to provide VPN access to their systems, Dillon says. “If you go back five years ago, you could count on one hand places that would give us the VPN. And now, I can count on one hand the places that won’t. It’s really come full circle.”

However, that’s not so true in the manufacturing space, where Wynright’s business has grown from about 5% of its total five years ago to about 20% today. “We’ve been successful in moving to the manufacturing side as we’ve entered into the robotics arena, with palletizing,” Dillon says. “It is a different world, though. VPN’s a little tougher to get, and don’t say the word ‘PC.’” **cd**

Technology in Action

Surface Finisher Makes a Modular Move

Corrotec Simplified Its I/O, Then Pneumatics, and Is Looking for More.

By Aaron Hand, Managing Editor

In the 37 years it's been in business, Corrotec (www.corrotec.com) has seen a lot of control and automation technologies change. "We've come a long way from drum encoders and relays," says Dan Edgington, project manager. "It's changed a lot in just the last five years."

Corrotec's equipment is primarily for surface finishing, including nickel plating and anodizing. The company's largest market is automotive, with equipment being used to plate brake caliber lines, seal plates, seat brackets—pretty much anything that's shiny, Edgington says. Aerospace also figures prominently; some equipment is used for titanium coatings on medical parts; and job shops use the machines for a large range of decorative and household items.

Perhaps what's changed the most in recent years is the automation's increasing modularity. "For the most part, our machines are built on-site," Edgington says, explaining that systems can run 60–70 ft long and just as wide. "We've really started to modularize things. We started with I/O, moving to Ethernet-based I/O blocks. We can plug in the Ethernet cable and power and be done with it."

The logical next step in the I/O block, Edgington says, was to modularize the pneumatics system.

Corrotec uses a lot of pneumatic valves for its diaphragm pumps for the material transfer of what Edgington calls "nasty chemistry"; and also to lift and lower rotary tables, open and close gates, etc. The machine builder considers pneumatics as the best option because of their suitability to chemistries. "We typically won't use hydraulics; if the oils get into the bath, it will destroy them," Edgington explains. "Some things can be done electrically. But it's a harsh environment, so a lot of electric actuators would fail."

Just a few months ago, Corrotec switched its pneumatics system to a more modular approach, and just like the company has done away with long runs of wiring, Edgington says, the new pneumatics system does away with long runs of tubing. The machine builder has started using Norgren's IVAC, which combines pilot and control valves, position



CORROTEC

CHEMICAL CHAOS

In surface finishing, machine downtime could mean thousands of ruined parts.

sensors and flow regulators in one unit. "You just screw it into the cylinder, supply compressed air, and then you're done," Edgington says. "If we can take three or four days out of installation, it lowers the installed cost for us, and the end user gets to go into production sooner. You get a direct payback on the machine in a short amount of time."

Taking a more modular approach helps not only with installation, but with maintenance as well. "With IVAC being a total unit, if it doesn't work properly, you just pull it out and put a replacement part in," Edgington says.

"Lost production time is a huge deal," he adds, noting that for plating processes, a machine going down could mean thousands of ruined parts. "If a machine goes down, and it's down for 10 minutes, but the parts are supposed to be in there for 30 seconds, that's a big deal. Everything in process becomes a few hours of lost work."

Modularization has probably taken two to three days off of pneumatics installation time and perhaps two weeks on the control side for Corrotec, Edgington says. "We can try to compress the install time, but you can only fit so many people in a small area," he says. "Eliminating a few miles of wiring is a direct savings." **cd**