



# PRESSURE MONITORING AND MANAGEMENT

## Pressure and Flow Data Logger





# MUELLER PRESSURE AND FLOW DATA LOGGER ENABLES YOU TO PLACE ACCURATE, RELIABLE AND AFFORDABLE DEVICES AT POINTS OF INTEREST IN YOUR NETWORK, CONFIGURE THEM, AND VIEW AND ANALYZE DATA FROM YOUR ENTIRE LOGGER ESTATE

### HIGH QUALITY

- Manufactured in the UK to externally audited 5S manufacturing standards
- Internationally recognized quality, environmental and security standards: ISO 19001
- High precision pressure transducers
- Designed and tested to IP68
- Wide range of temperature and humidity operating conditions
- Drop tested to 4 ft impact on concrete
- Built to order with 1 week lead time

### EASE OF USE

- Installation and configuration using laptop, mobile or tablet
- Internal or external battery, or mains powered
- SIM card and battery easily exchanged by user in the field
- Quick-fit hoses, cam-lock screws and cable tie mount for quick installation
- Wide range of antenna options
- Small size and light weight

### MOST USEFUL DATA

- Up to 3 pressure measurements and 2 flow channels from a single logger
- 145 psi transducers fitted as standard, 435 psi transducers are available at no additional cost
- Communications options are NB-IoT and LTE-M
- Threshold and decaying alarms
- Enhanced statistics for transient detection and investigation



MUELLER LOGGERS CAN BE USED TO MONITOR PRESSURE AND FLOW AT ANY POINT OF INTEREST IN THE NETWORK.

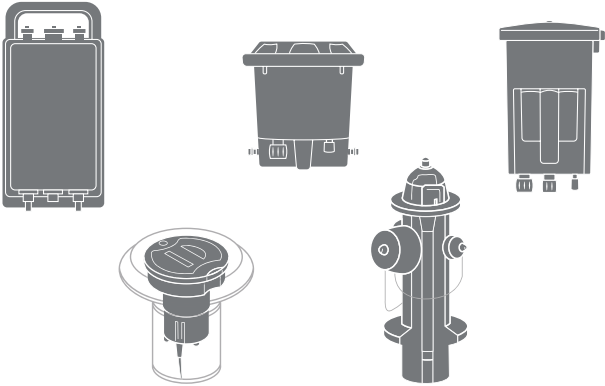

MUELLER PRESSURE AND FLOW DATA LOGGER PRESSURE AND FLOW DATA LOGGER CAN ALSO INGEST DATA FROM YOUR MUELLER RPM AND MUELLER SMART HYDRANT TO PROVIDE A UNIFIED VIEW OF YOUR NETWORK.

- Records mobile network signal strength and battery voltage
- Ability to carry out on-site readings from logger
- Non-volatile data storage up to a year
- Remotely configurable sampling, logging and dial-up intervals
- Data can be exported or integrated with other systems

### LOWEST LIFETIME COST

- Competitive pricing with 3 year warranty as standard
- More than 5 years battery life from internal battery
- Over-the-air firmware upgrades deliver new functionality
- No return to base for recalibration, battery or SIM change
- Loggers remotely upgradeable to PRV controller
- Ongoing service and technical support at no additional cost

# PRESSURE AND FLOW DATA FROM POINTS OF INTEREST ON YOUR NETWORK



## VISUALIZATION

Mueller Pressure and Flow Data Logger visualizes data in ways that make it easier for engineers to identify anomalies, whether they are threshold breaches or patterns of abnormal performance. The principles of effective visualization are:

- Easy to view
- Quick to update
- Easy to navigate
- Context brings meaning

Mueller Pressure and Flow Data Logger offers the user main views of data: graphing and dashboard. Context is provided in multiple ways including: showing a zoomed view in the context of a 12 month view, a location in a network hierarchy or in its geographical location, and presenting all locations in a sortable single view.

## ALARMS

Alarm thresholds can be individually set for each flow and pressure channel. Alarms trigger the following actions:

- Send an SMS and/or an email containing alarm details
- Dial up with increased regularity

A Nightline period can be defined and alternative thresholds can be set for a flow channel to aid breach and burst detection.

When an alarm is raised the decaying process is triggered, with data delivered at the intervals shown above. When the alarm is cleared the decay process is canceled. Data is delivered at this point and then 2 hours later for post-event analysis.



ABOVE: ZOOMED VIEW OF A SINGLE LOCATION SHOWING MULTIPLE PARAMETERS  
BELOW: SPARKLINE VIEW OF ALL PARAMETERS AT ALL LOCATIONS AT A GLANCE



## ENTERPRISE EDITION

If you already have alarm, visualization or business intelligence software, Mueller Pressure and Flow Data Logger is available in an Enterprise Edition. You can install it directly on your servers and set it up to deliver data to your existing systems. It can be integrated with your Active Directory, giving the benefits of single sign-on, and enabling you to manage user security.

Mueller Solutions are available as SaaS, some in enterprise editions. Clients repeatedly choose SaaS for three main reasons:



### THE FASTEST WAY TO DELIVER

- Works anywhere
- Easy to use
- Immediately available



### NO HASSLE

- Guaranteed levels of service
- Seamless upgrades
- Zero infrastructure
- High levels of security



### AFFORDABLE

- No significant up-front costs
- Simple annual fee
- Scalable

**For more information about Mueller or to view our full line of water products, please visit [i2owater.com](https://www.i2owater.com) or call Mueller customer service at 1.800.423.1323.**

Mueller refers to one or more of Mueller Water Products, Inc. a Delaware corporation ("MWP"), and its subsidiaries. MWP and each of its subsidiaries are legally separate and independent entities when providing products and services. MWP does not provide products or services to third parties. MWP and each of its subsidiaries are liable only for their own acts and omissions and not those of each other. MWP brands include Mueller®, Echologics®, Hydro Gate®, Hydro-Guard®, HYMAX®, iZO®, Jones®, Krausz®, Mi.Net®, Milliken®, Pratt®, Pratt Industrial®, Singer®, and U.S. Pipe Valve & Hydrant. Please see [muellerwp.com/brands](https://muellerwp.com/brands) and [i2owater.com](https://i2owater.com) to learn more.

© 2021 Mueller Systems, LLC. All Rights Reserved. The trademarks, logos and service marks displayed in this document are the property of Mueller Systems, LLC., its affiliates or other third parties. Products above marked with a section symbol (§) are subject to patents or patent applications. For details, visit [www.mwppat.com](https://www.mwppat.com). These products are intended for use in potable water applications. Please contact your Mueller Sales or Customer Service Representative concerning any other application(s).